

# The Wedding Cake (#5001)

## Installation Procedures

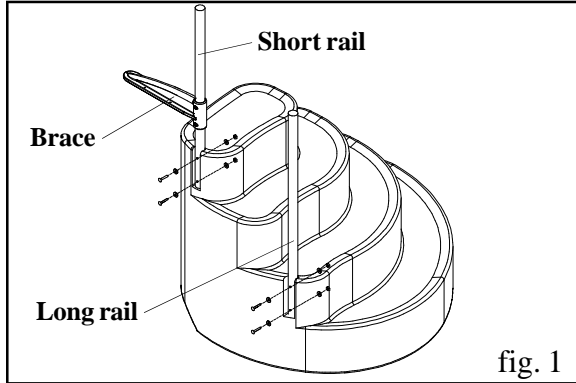

fig. 1

1. Place the rails on the side of the step (short rail on top) and align with the predrilled holes. Attach using the 2-3/4" bolts, washers, and nuts. Do not tighten the bolts at this time. Slide the brace over the short rail (fig. 1).

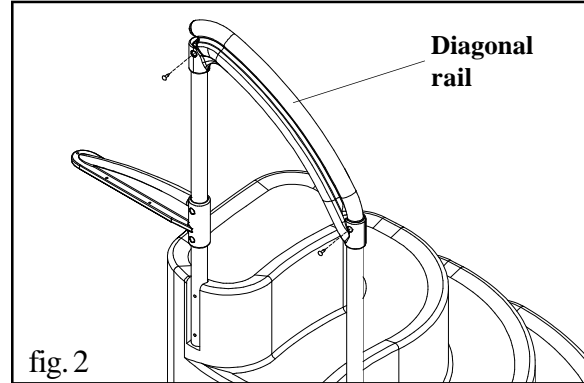

fig. 2

2. Insert the diagonal rail onto the long and short rails. Drill 1/8" holes on the long and short rails through the predrilled holes of the diagonal rail from the outside of the step. Attach using the 5/8" screws (fig. 2). Tighten the bolts on the step (as shown in figure 1).

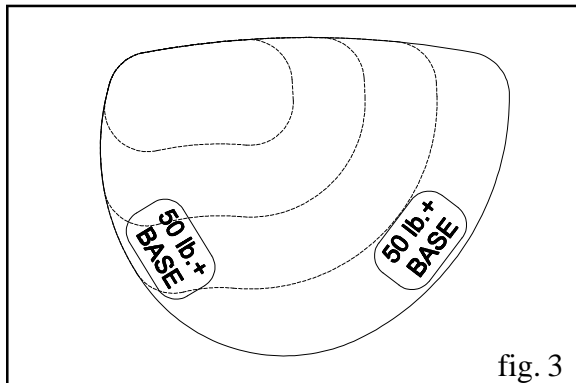

fig. 3

3. Place 2 sandbags\*, or equivalent weights (min. 50 lbs. each), inside the step and push them to the sides and front (fig. 3).

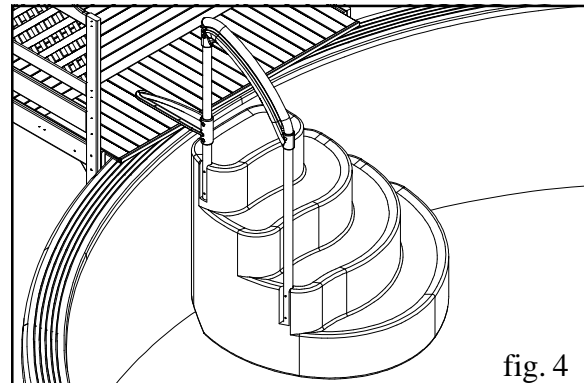

fig. 4

4. Move the step in the water and allow the air to escape. Place the step against the pool wall and ensure that the step touches the ground solidly. Lower the brace until it rests on the deck (fig. 4).

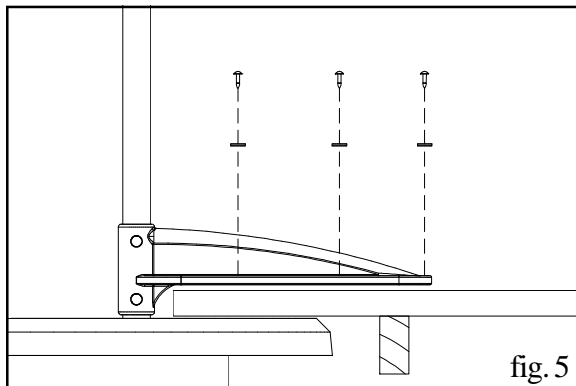

fig. 5

5. Attach the brace to the deck using the 1-3/4" screws and washers. If the deck is above the toprail, attach the brace directly to the deck (fig. 5).

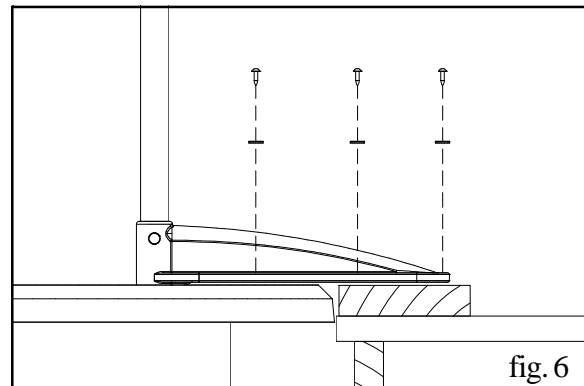
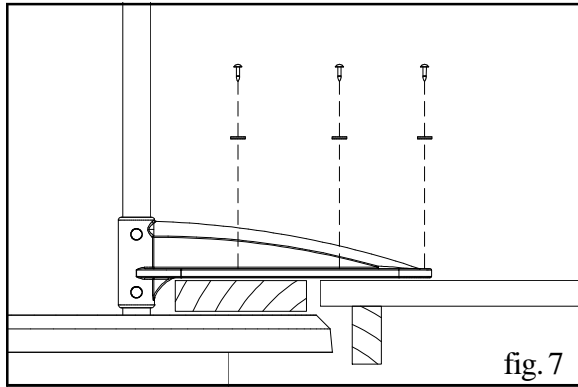
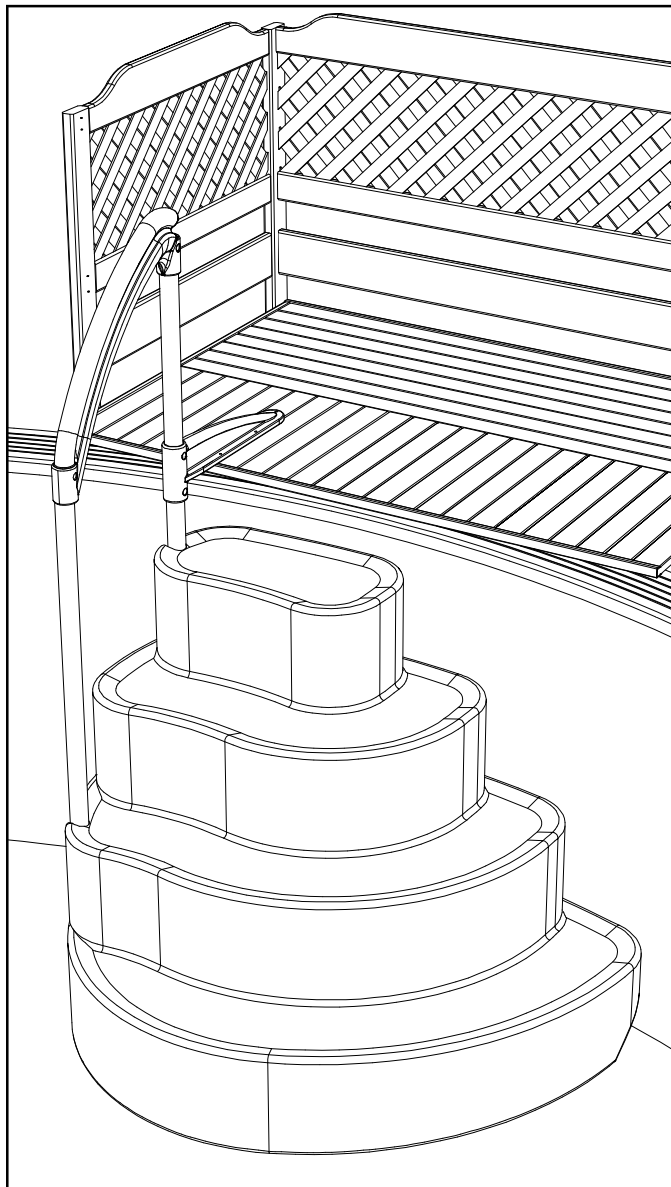

fig. 6

6. If the deck is lower than the pool, the brace should be shimmed\* to attain the same level as the pool (fig. 6). Ensure the shim is properly secured to the deck.



7. If the pool is lower than the deck, the brace should be shimmed\* to attain the same level as the deck (fig. 7). Ensure the shim is properly secured to the top rail.



**Caution:**

- Locate the step on a solid base.
- Do not jump or dive from the step.
- The step should be removed from the water when temperatures drop below freezing.
- Never lift the step by its rails.
- Use battery-operated tools to avoid electric shock near water.
- Ensure no corrosive materials are added to the step.
- The step shall be installed per manufacturer's instructions.
- File off all stripped or sharp edges of hardware to avoid injury.
- The manufacturer is not responsible for damages or injuries caused by improper installation or use.

\* Not included with the step.

