

SECTION VII. TECHNICAL DATA

A. REPLACEMENT PARTS

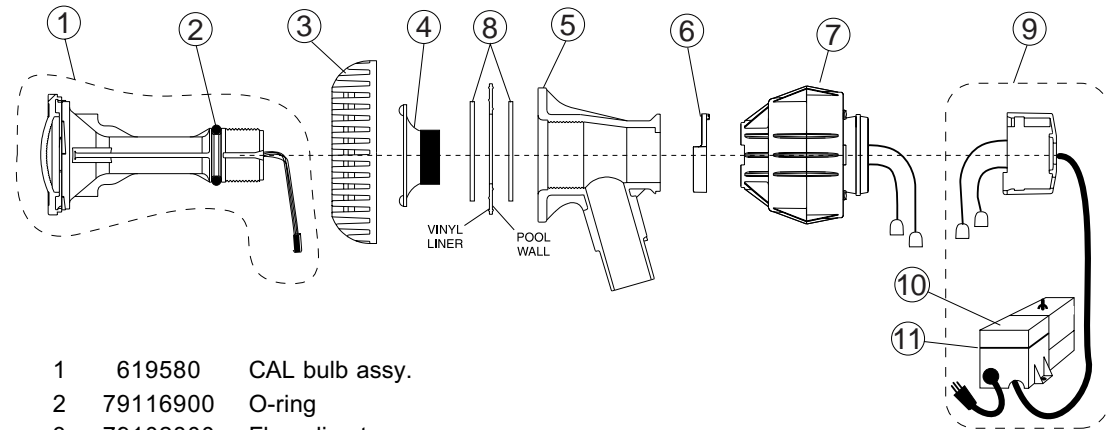

1	619580	CAL bulb assy.
2	79116900	O-ring
3	79102800	Flow director
4	79118300	Wall flange, threaded
4	79126900	Body fitting
6	619545	Clip Washer
7	619544	Control, PCB assy.
8	79116800	Gasket, 2 req.
9	83000000	Transformer assy. with cord and cap
10	619552	J-Box assy.
11	79401000	J-Box gasket
	79110700	Spacer, mounting

SAVE THESE INSTRUCTIONS.

Pentair Water Pool and Spa, Inc.

1620 Hawkins Ave., Sanford, NC 27330 • (919) 566-8000
 10951 West Los Angeles Ave., Moorpark, CA 93021 • (805) 523-2400
 Visit us on the Internet at: www.pentairpool.com



© 2004 Pentair Water Pool and Spa Incorporated. All rights reserved. Information in this document is subject to change without notice.

Trademarks and Disclaimers. The *Pentair Water Pool and Spa logo* and CAL are trademarks of Pentair Water Pool and Spa Incorporated. AquaLuminator is a registered trademark of Pentair Water Pool and Spa Incorporated. Other trademarks and trade names may be used in this document to refer to either the entities claiming the marks and names of their products. Pentair Water Pool and Spa Incorporated disclaims any proprietary interest in trademarks and trade names other than its own.

CAL™ (Color AquaLuminator®) Light and Return Water Flow for Above Ground Pools Owners Manual

IMPORTANT SAFETY INSTRUCTIONS
READ AND FOLLOW ALL INSTRUCTIONS
SAVE THESE INSTRUCTIONS

Table of Contents

SECTION I.	IMPORTANT SAFETY INSTRUCTIONS	2
SECTION II.	LAMP HOUSING INSTALLATION	2
SECTION III.	ELECTRICAL CONNECTIONS FOR STORABLE POOLS	5
SECTION IV.	ELECTRICAL CONNECTIONS FOR PERMANENT POOLS	6
SECTION V.	RELAMPING INSTRUCTIONS	9
SECTION VI.	STORAGE AND WINTERIZING INSTRUCTIONS	11
SECTION VII.	TECHNICAL DATA	12
A.	Replacement Parts	12

WARNING

Before installing this product, read and follow all warning notices and instructions accompanying this light. Failure to follow safety warnings and instructions can result in severe injury, death, or property damage. Call (800) 831-7133 for additional free copies of these instructions.

Important Notice



Attention Installer.

This manual contains important information about the installation, operation and safe use of this product. This information should be given to the owner/operator of this equipment.



Pentair Water Pool and Spa, Inc.

1620 Hawkins Ave., Sanford, NC 27330 • (919) 566-8000
 10951 West Los Angeles Ave., Moorpark, CA 93021 • (805) 523-2400
 Visit us on the Internet at: www.pentairpool.com



SECTION I. IMPORTANT SAFETY INSTRUCTIONS

When installing and using this electrical equipment, basic safety precautions should always be followed, including the following.

1. This light can be installed on storable above ground or permanent above ground pools.
2. A storable pool has a maximum water depth of 42 inches and is so constructed that it may be readily disassembled for storage and re-assembled to its original integrity.
3. A permanent pool has a maximum water depth of over 42 inches. Do not install on therapeutic pools, hydro-massage bathtubs, spas or hot tubs.
4. To reduce the risk of electric shock, if any cord becomes damaged, return the entire transformer assembly for repair or replacement.
5. Risk of entrapment, injury or death. Use plumbing passageways only to return water to pool. Do not use as a suction device.
6. Risk of electrical shock. Connect only to a grounding type circuit protected by a ground fault circuit interrupter (GFCI). Contact a licensed electrician if you cannot verify that the receptacle or circuit is protected by a GFCI. Do not use an extension cord.
7. Locate your pool so that the wall is at least 10 feet from all electrical receptacles and at least 20 feet from all receptacles not protected by a GFCI. It is also very important to locate the pool so that it is not under any electrical wiring, that is less than 18 feet vertically above the pool wall and within an area located 10 feet outside the pool walls. The pool must also never be located under any lighting fixture or within five (5) feet measured horizontally from any fixture mounted less than five (5) feet vertically above the pool water level.
8. Risk of injury. Install the top of the lens with a minimum of 8 inches and a maximum of 10 inches below top of pool wall or in manufacturers pre-punched return fitting hole.
9. Do not use electrical equipment within 10 feet of pool wall unless specifically U.L. listed for that use.

SECTION II. LAMP HOUSING INSTALLATION

NOTE

Installation of the lamp housing into the pool wall is the same for both the storable and the permanent above ground pools.

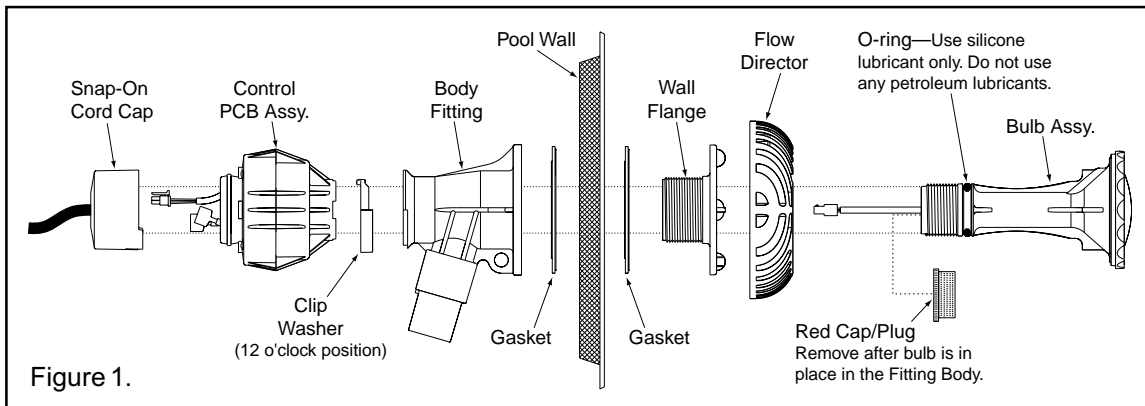

SECTION VI. STORAGE AND WINTERIZING INSTRUCTIONS

1. It is common practice to drain the water level to a point below the skimmer and the light, for winterizing.
2. **For storable pools:** remove power from the unit by taking the power cords' three-prong plug and disconnecting it from its electrical outlet.
For permanent pools: turn off all electrical power supplying the light circuit at the main circuit breaker.
3. Remove the snap-on cord cap by inserting a slotted screwdriver into the access hole and prying upwards, as illustrated in Figure 21, in the relamping instructions.
4. The wire connectors should be gently disconnected and pushed into the rear of the bulb assembly.
5. With the end of a flat head screw driver, push the plastic stopper in the clip washer forward towards the front of the light, see Figure 22.
6. With the plastic stopper pushed forward, unthread the controller out of the bulb body.
7. Remove the clip washer from the bulb body.
8. Push red cap/plug into rear of bulb assembly to seal it.
9. Remove the bulb assembly by pulling on the flow director while pushing the bulb assembly from the outside of the pool.

NOTE

The body fitting, threaded wall flange and gaskets may remain attached to the pool wall when winterizing, but should be removed if pool is to be stored.

10. **For storable pools:** remove the transformer from its mounting by lifting up and out.

For permanent pools: cover the cord cap on the end of the flexible cord with a plastic bag and seal with a twist tie or rubber band. Wrap the cord into a coil, cover with a plastic bag and seal. Elevate cord to prevent contact with ground moisture.

11. Place all the parts together in a box and store indoors.

When reinstalling bulb assembly next season do not use petroleum base product.

<h2>CAUTION</h2>	
	<p>Do not use any petroleum base lubricant. Petroleum base products will destroy plastic parts. Lubricate o-ring with a silicone lubricant only. A new o-ring should be used each time the bulb assembly is removed.</p>

12. If applicable, take the red cap/plug off and gently bring the wire connectors through the back side of the bulb assembly. Save the red cap/plug for storage and winterizing.
13. Slide clip washer into position with the plastic stopper at the 12 o'clock position as shown in Figure 1.
14. Feed wire from the bulb body through the center hole of the controller as you align the controller with the bulb body.
15. Thread the controller and the bulb body together until light is secured in wall.

	CAUTION
Do not over tighten as adjustability of flow director may be impaired and/or damage to parts causing leakage may occur. If flow director does not rotate by hand, nut is too tight.	

16. For safety purposes, ensure that plastic stopper in clip washer is within one of the slots in the controller. This will prevent the controller from coming loose unexpectedly, see Figure 9.
17. Connect together the black connector from the bulb body with the black connector from the controller.
18. Connect the wire connectors from the bulb assembly to the wire connectors attached to the snap-on cord cap. Make sure to use the correct bulb assembly unit for a CAL light, see Figure 20. *The wrong bulb assembly will permanently damage light.*

NOTE

There is no polarity (no positive or negative) to the wires, either connection will work.

19. Snap cap onto end of body so that the electrical cord is pointing down; see Figure 13.

WARNING	
	Risk of electric shock. Connect only to a circuit protected by a GFCI. Failure to do so can result in death and/or serious injury.

20. Reconnect the power to a circuit in accordance with the appropriate electrical connections. See Sections III and IV, Electrical Connections. If the light is not on, press the switch on the transformer case *once*.

WARNING	
	This is an electrical appliance. Unsupervised use of this product by children can result in injury and/or death.

1. Push the bulb assembly out from the rear of the body fitting so that it will come out of the front of the fitting. The flow director will come off along with the bulb assembly; see Figure 2. Push the red cap/plug in the end of the bulb assembly. It will be removed later.
2. Unscrew the threaded wall flange from the body fitting by rotating it counter-clockwise.

NOTE

Retain the gaskets supplied and keep them accessible.

3. Use the Teflon™ tape provided. Snugly wrap the threaded wall flange in a clockwise direction (as viewed from the back) starting at the edge of the threads; see Figure 3. Work towards the wall flange lip (overlapping 1/2 of the tape width with each wrap) then back towards the starting point.
 - If you have a new pool, move on to Step 10.
 - If the water level is below the return fitting on an existing pool, remove the old fitting and move on to Step 10.
 - If the pool is full of water, follow Steps 5 through 9.

NOTE

Steps 4 through 8 require two (2) No. 9 winterizing plugs (not supplied).

4. Remove the existing eyeball fitting from the return fitting on your pool wall, see Figure 4.
5. Place a winterizing plug in the front side of the existing return fitting and disconnect the return hose and clamp from the existing fitting.
6. Place a winterizing plug in the front side of the CAL threaded wall flange.
7. While holding the existing return fitting from the inside of the pool, remove the large nut or the existing body fitting on the outside of the pool wall.
8. Using a folded rag in the palm of your hand, push the old return fitting out of the wall from the outside of the pool; see Figure 5. Hold the rag firmly against the wall to prevent water spillage.
9. Insert the wall flange and gasket from the inside of the pool through the hole cut out for the inlet fitting. Ensure that the threaded wall flange is centered on the hole.
10. Take the remaining gasket and put it on the threaded wall flange from the outside of the pool; see Figure 1. Standard sheet metal walls will have one gasket and one spacer left over. Do not use these two items, as they are for use on narrow interlocking wall panels only.

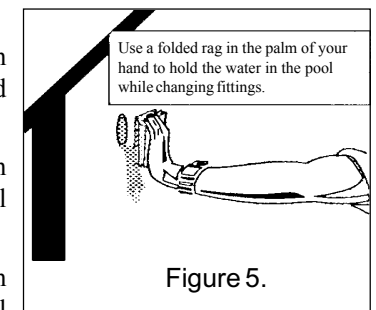
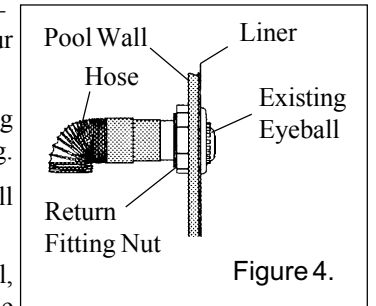
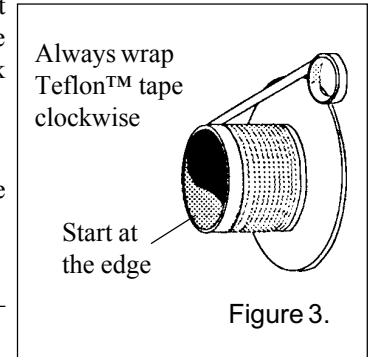
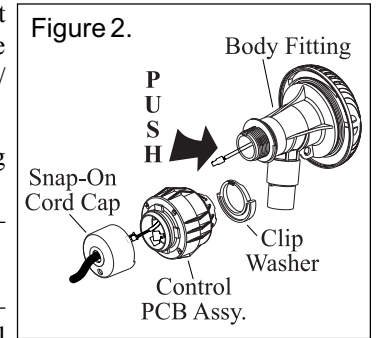

NOTE

- For narrow, interlocking, extruded aluminum wall panels, center wall flange between the ridges while viewed from the inside of the pool. Add the spacer and additional gasket to the wall flange before inserting the wall flange through the wall panel.
- **The spacer and additional gasket is necessary to accommodate a fountain attachment.**

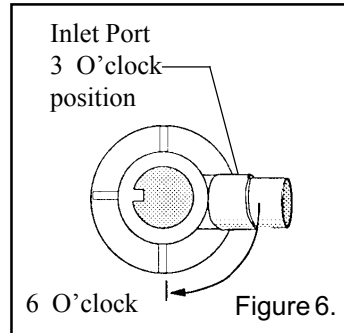

WARNING

The light fixture must be mounted so that the word "top" is at the top of the fixture when installed. Incorrect orientation and a low water condition can damage the light fixture.

11. With the inlet port of the body fitting in the 3 O'clock position, place the body fitting against the threads of the wall flange and keeping the inlet port in the 3 O'clock position; see Figure 6. Hand tighten the wall flange as tight as possible. Rotate the wall flange, not the body.

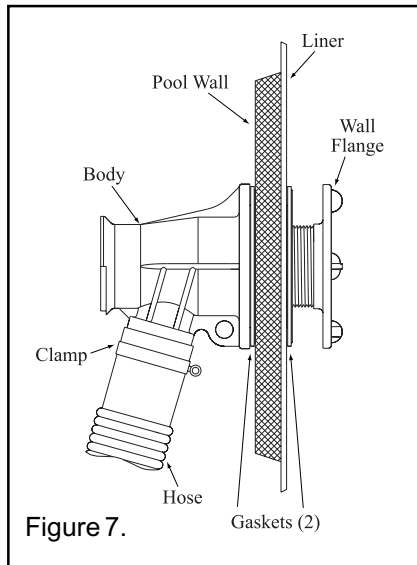

Figure 7.

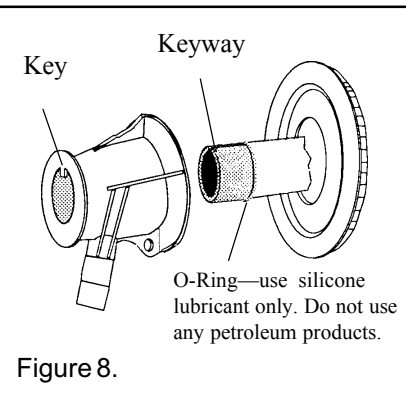

Figure 8.



CAUTION

Do not over tighten the wall flange.

12. To complete the tightening process, hold the wall flange in place and rotate the body fitting until the inlet port is in the 6 o'clock position; see Figure 6.
13. Take a hose clamp and place it over the return hose cuff.
14. Slip the return hose from the equipment, over the inlet port, and tighten the hose clamp securely; see Figure 7.
15. If applicable, remove winterizing plug that was applied in Step 6.
16. Take the bulb assembly and insert it through the flow director. Note the aligning keyway on the bulb assembly as shown in Figure 8. The keyway must point in the same direction as the top key on the body fitting.
17. Now, from inside the pool, push the bulb assembly and flow director with the red cap/plug in place into the body fitting until the bulb assembly/flow director are nearly flush against the inside pool wall.
18. Slide clip washer into position with the plastic stopper at the 12 o'clock position as shown in Figure 1.
19. Feed wire from the bulb body through the center hole of the controller as you align the controller with the bulb body.

SECTION V. RELAMPING INSTRUCTIONS

WARNING



Risk of electric shock. Disconnect power before servicing this unit. Failure to disconnect power can result in death or severe personal injury.

1. When replacing the bulb assembly, make sure to use the correct bulb assembly unit for CAL light, see Figure 20.
2. It is desirable to reduce the water level to the lower edge of the flow director. This makes bulb assembly replacement easier, but it is not mandatory.
3. Remove power from the unit by taking the power cord's 3-prong plug and disconnecting it from its electrical outlet, or in the case of a hard-wired application, by turning the respective circuit breaker to the OFF position.

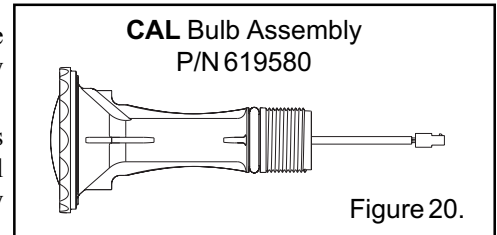

Figure 20.

4. Remove the snap-on cord cap by inserting a slotted screw driver into the access hole, as illustrated in Figure 21, and prying upwards.
5. Disconnect all three wire connectors and put the snap-on cord cap aside in a dry location.
6. With the end of a flat head screw driver, push the plastic stopper in the clip washer forward towards the front of the light, see Figure 22.
7. With the plastic stopper pushed forward, unthread the controller out of the bulb body.
8. Remove the clip washer from the bulb body.
9. At this point you should have the new replacement bulb assembly accessible and confirm that the red cap/plug is pressed firmly into the bulb assembly to prevent water from entering the bulb assembly.
10. If you were able to lower the water level as suggested in Step 1, then simply remove the old bulb assembly by pulling on the flow director while pushing the bulb assembly from the outside of the pool. If you were unable to lower the water level, follow these instructions: push the bulb assembly out from the outside of the pool, keeping the back of the fitting covered with a folded rag in the palm of your hand to prevent water loss from the rear of the body fitting; see Figure 5. Pull the flow director and bulb.
11. Take the new replacement bulb assembly with the red cap/plug in place and insert it through the flow director. Note the aligning keyway on the bulb assembly as shown in Figure 8. The keyway must point in the same direction as the top key on the body fitting.

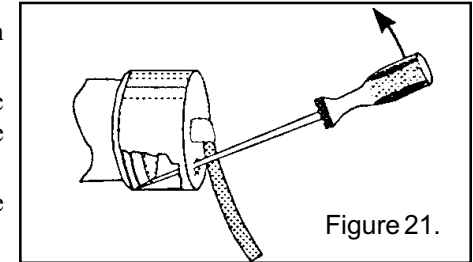

Figure 21.

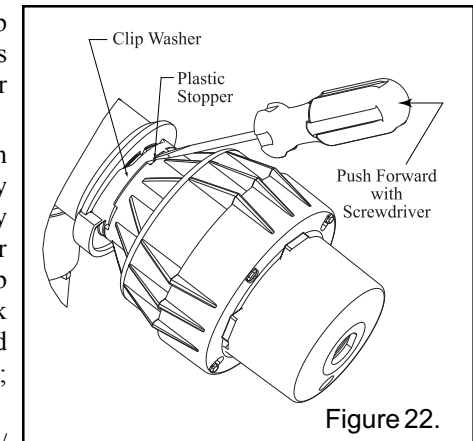

Figure 22.

Now, from inside the pool, push the bulb assembly with the flow director into the body fitting until both are nearly flush against the inside pool wall. You can now remove your hand and the fitting should again be sealed.

- Mount the transformer box on a pool support approximately 18 inches above the ground, in a position accessible to electrical connection; see Figure 17. To mount the transformer junction box, insert one of the screws provided, to a pool support.

NOTE

Do not install the transformer directly onto the pool wall.

- Pull cord out of the junction box and strip a six (6) inch section of the outer insulation jacket from the cord, see Figure 18.

⚠ WARNING



Risk of electric shock. Connect only to a circuit protected by a GFCI. Failure to do so can result in serious personal injury and/or death.

- Connect the conduit to the junction box. Make electrical connections in the junction box. Reinstall the cover to the junction box.
- Using the cable clamp provided, attach the cable clamp to the cord and mount the cable clamp to the pool support, see Figure 19, so that the cord lies flush against the pool wall. Do not attach directly to the pool wall. This will keep the cord flush to the wall; see Figure 17.
- Make electrical connections to the power supply protected by a GFCI. Turn on the power.
- If the light is not ON, press the switch on the transformer case *once*.

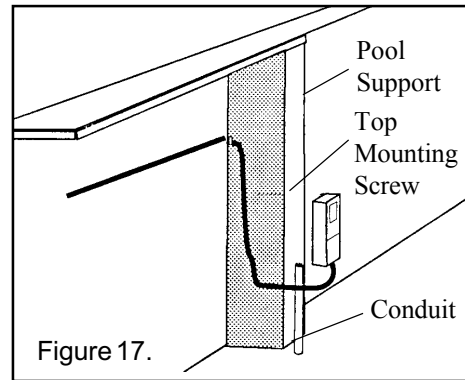

Figure 17.

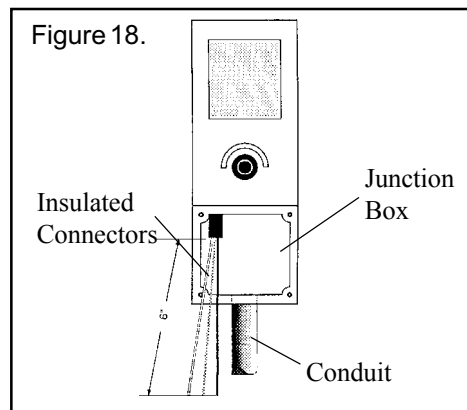

Figure 18.

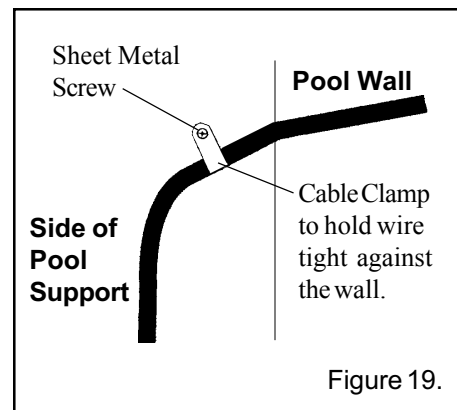

Figure 19.

- If applicable, take the red cap/plug off and gently bring the wire connectors through the back side of the bulb assembly. Save the red cap/plug for storage and winterizing.
- Thread the controller and the bulb body together until light is secured in wall.
- For safety purposes, ensure that plastic stopper in the clip washer is within one of the slots in the controller. This will prevent the controller from coming loose unexpectedly, see Figure 9.



⚠ CAUTION

Do not over tighten as adjustability of flow director may be impaired and/or damage to parts causing leakage may occur. If low director does not rotate by hand, nut is too tight.

- Connect together the black connector from the bulb body with the black connector from the controller.

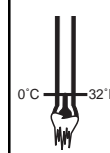

⚠ CAUTION

This lighting fixture may be damaged if subjected to freezing weather. See winterizing instructions for details on how to store the bulb assembly.

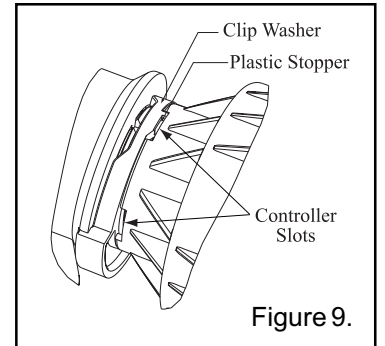

Figure 9.

SECTION III. ELECTRICAL CONNECTIONS FOR STORABLE POOLS

- Connect the wire connectors from the bulb assembly to the wire connectors attached to the snap-on cord cap.

NOTE

There is no polarity (no positive or negative) to the wires, either connection will work.

- Snap the cap onto the end of the body so that the electrical cord is pointing down.
- Mount the transformer on the vertical wall using the single screw provided.
- Plug the power cord's 3-prong plug into an appropriate 110V GFCI protected receptacle at least 10 feet from the pool.
- If the light is not on, press the switch on the transformer case *once*.

⚠ WARNING



Risk of electric shock. Connect only to a grounding-type receptacle protected by a GFCI. Do not use extension cords for connection. Failure to do so can result in death or severe personal injury.

??? WHAT IS A GFCI ???

A 'Ground Fault Circuit Interrupter' is an electrical safety device designed to measure electrical leakage in a circuit. It is far more sensitive than a standard circuit breaker. GFCI equipped breakers and outlet combinations react to unsafe leakage and shut the power off before electrical shock injury can occur. Any electrical device used within 10 feet of a pool must be protected by a GFCI equipped outlet or a GFCI equipped circuit breaker and be intended for such use.

SECTION IV. ELECTRICAL CONNECTIONS FOR PERMANENT POOLS

NOTE

To install the transformer assembly for permanent above ground pools, several modifications must be completed.

⚠ WARNING



Disconnect all power before cutting cords to length. Failure to do so could result in personal injury and/or death.

This installation requires cutting the two cords to specified lengths.

Risk of electrical shock. Permanent installations must be performed by a licensed electrical professional in accordance with the National Electrical Code and any Local Codes that apply. Failure to do so could result in personal injury and/or death.

1. Identify the cord from the transformer assembly to the snap-on cord cap and cut it at a distance of five (5) feet from the transformer assembly; see Figure 10.
2. Strip a 2 inch section of the outer insulation jacket from the cord. This will expose the two insulated conductors of the cord; see Figure 11.

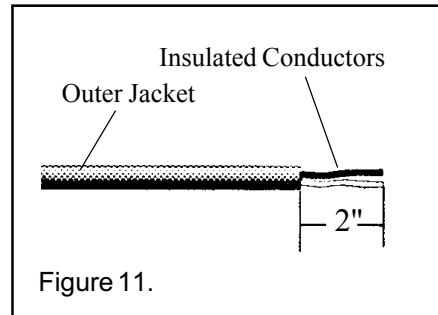
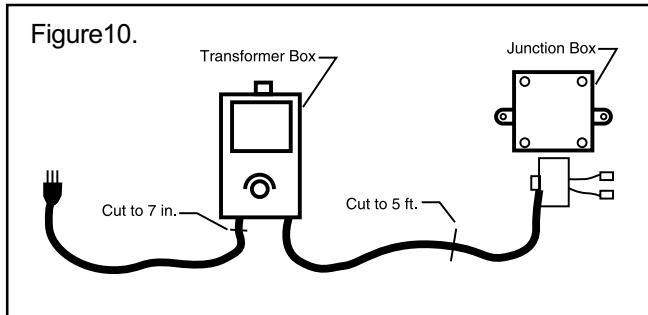

3. Remove the strain relief and the snap-on cord cap from the cut section of cord. To remove the strain relief it is necessary to use a pair of strain relief pliers; if these are not available, then a pair of needle-nose pliers can be used. Compress the lower tab against the upper part of the strain relief from the inside of the cap while pushing the cord and the strain relief through the cap; see Figure 12.
4. Route cord through the cord hole in the body; see Figure 13.

⚠ WARNING



Do not attach or hang anything but this cord from the cord cap through the hole in the body to the transformer housing. Attaching or hanging items from this location can result in failure to the body or the pool wall which can result in serious personal injury and/or property damage.

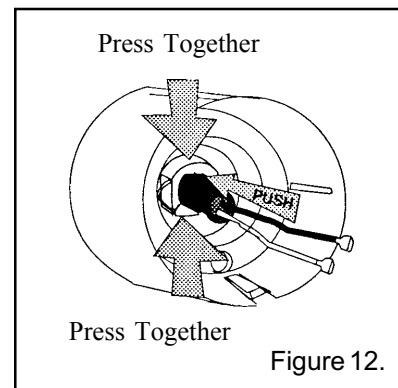

5. Reinstall the snap-on cord cap to the stripped end of the cord leaving 1/4 inch black insulation protruding into the cap with the strain relief positioned as illustrated in Figure 14.

NOTE

Strain relief must be reinstalled at the end of the outer insulation jacket. This will leave the two insulated conductors extending from the inside of the snap end of the cord cap.

6. Strip the insulation back 1/4 inch on the two insulated conductors and install the two wire connectors provided into the end of each insulated conductor using a crimping pliers.
7. Connect the wire connectors from the bulb assembly to the wire connectors attached to the snap-on cord cap.

NOTE

There is no polarity (no positive or negative) to the wires, either connection will work.

8. Snap the cap onto the end of the body so that the electrical cord is pointing down.
9. Cut off the cord with the 3-prong plug seven (7) in. from where it exits the transformer box; see Figure 10. Discard the remaining cord and plug.
10. Insert the cord from the plug through the smooth hole and then insert the cord through the threaded hole. Slide the cord from the light assembly into the angled slot on the junction box bottom. Make sure the cord by the transformer box starts by the deep end of the angled slot; see Figure 15.
11. Place the junction box cover on the junction box bottom so that the junction box can more easily snap into the transformer box; see Figure 16. Snap the pieces together, then remove junction box cover.

