





# IntelliChlor® Electronic Chlorine Generator (Model IC15)



## Installation and User's Guide



 **UL** US LISTED SWIMMING POOL AND SPA CHLORINATOR 30ZR  
Patents pending

 Certified to NSF/ANSI 50

IMPORTANT SAFETY INSTRUCTIONS  
READ AND FOLLOW ALL INSTRUCTIONS  
SAVE THESE INSTRUCTIONS



**WARNING** - Salt is an inherently corrosive material. While the levels of salt required for proper operation of the IntelliChlor Electronic Chlorine Generator are relatively low when compared to sea water and other salt solutions, placing any amount of salt in your pool increases the likelihood of corrosion or other deterioration of pool equipment and any surfaces used in and around your pool. Metal parts and certain natural and man-made surfaces are particularly susceptible to corrosion and deterioration when used in and around salt water pools. Pentair Water Pool and Spa does not represent or otherwise guarantee that the proper use of the IntelliChlor Electronic Chlorine Generator will prevent corrosion or other deterioration of pool equipment and any surfaces used in and around your pool. Consult your experienced pool professional, who should be able to advise you on the proper material selection, installation techniques for those materials, and the proper use, care and maintenance of those materials for your specific pool type and location in order to minimize the corrosion and deterioration that is inherent in and around salt water pools.

© 2009 Pentair Water Pool and Spa, Inc. All rights reserved

**This document is subject to change without notice**

1620 Hawkins Ave., Sanford, NC 27330 • (800) 831-7133 • (919) 566-8000  
10951 West Los Angeles Ave., Moorpark, CA 93021 • (800) 831-7133 • (805) 553-5000

EasyTouch®, IntelliChlor®, IntelliFlo®, SunTouch® and Pentair Water Pool and Spa® are trademarks and/or registered trademarks of Pentair Water Pool and Spa, Inc. and/or its affiliated companies in the United States and/or other countries. Unless noted, names and brands of others that may be used in this document are not used to indicate an affiliation or endorsement between the proprietors of these names and brands and Pentair Water Pool and Spa, Inc. Those names and brands may be the trademarks or registered trademarks of those parties or others.

# Contents

<b>Important Safety Precautions</b> .....	<b>iii - iv</b>
Technical Support .....	iv
IntelliChlor® Electronic Chlorine Generator Overview .....	1
Features .....	1
IntelliChlor Electronic Chlorine Generator Control Panel and Cell Description .....	2
IntelliChlor System Components .....	2
IntelliChlor Power Supply .....	3
Loop Plumbing Diagram .....	4
System Schematic Diagram .....	4
IntelliChlor Plumbing Diagram .....	5
<b>Section 1: IntelliChlor Control Panel</b> .....	<b>7</b>
Salt Level Status LEDs .....	7
Status LEDs .....	7
Sanitizer Output LED Indicators .....	8
More and Less Output Buttons .....	8
Self-Cleaning .....	8
<b>Section 2: Pool Water and Chemistry, Conditions and Precautions</b> .....	<b>9</b>
Pool Water Chemistry, Conditions and Precautions .....	9
Optimum Pool Water Conditions for Salt Water Pools (using the IntelliChlor Electronic Chlorine Generator) .....	10
Covered Pools and Vinyl Liner Pool and Lowering Chlorine Output Levels .....	10
Chlorine Testing .....	11
What Type of Salt to Use .....	11
How Much Salt to Use? .....	11
Calculating the Saturation Index .....	12
Saturation Index Factors .....	12
How to Add Salt to the Pool .....	13
Table 1. Approximate Pounds (Kg) of salt needed to obtain 3,400 ppm in pool .....	13
Table 2. Approximate Pounds (Kg) of salt needed to maintain 3,000 ppm in pool .....	14
Table 3. Approximate amount of cyanuric acid to obtain 75 ppm in pool .....	14
Pool Water Preparation .....	15
Determining Pool Size (Gallons of Water in Your Pool) .....	15
Determining Pool Size (liters of water in your pool) .....	15
<b>Section 3: Operating IntelliChlor</b> .....	<b>17</b>
Initial Start up Period .....	17
Operation .....	17
Use of an external Pool Pump Timer is not required .....	17
If you use a Pool Pump Timer .....	17
Startup Procedure (Super Chlorination) .....	18
Sanitizer Output Settings and Adjustments .....	18
Operating in Winter .....	18
General Recommendations .....	19
General Cautions .....	19
<b>Section 4: User Maintenance</b> .....	<b>21</b>
Daily service .....	21
Weekly service .....	21
Monthly Service .....	21
IECG Usage Hours Meter .....	22
Cleaning the IECG Cell Blades .....	22
Winterizing .....	23

<b>Section 5: Installation .....</b>	<b>25</b>
Kit Contents .....	25
Required Tools .....	25
IntelliChlor “Dummy” Cell .....	26
Installing the IntelliChlor Cell Assembly .....	26
Connecting the Power Supply Cable to the IC15 Cell .....	27
<b>Section 6: Troubleshooting .....</b>	<b>29</b>
Table 1: Troubleshooting .....	29
System Specifications and Wiring .....	31
110 VAC Basic System Wiring .....	32
Warranty .....	33

### **Technical Support**

**Sanford, North Carolina** (8 A.M. to 5 P.M. Eastern Time)

**Moorpark, California** (8 A.M. to 5 P.M. Pacific Time)

**Phone:** (800) 831-7133

**Fax:** (800) 284-4151

### **Web sites**

visit [www.pentairpool.com](http://www.pentairpool.com) and [www.staritepool.com](http://www.staritepool.com)

# IMPORTANT SAFETY PRECAUTIONS

SAVE THESE INSTRUCTIONS



**Important Notice: Attention Installer:** This manual contains important information about the installation, operation and safe use of this product. This information should be given to the owner and/or operator of this equipment. When installing and using this electrical equipment, basic safety precautions should always be followed, including the following:



**⚠ WARNING: IMPORTANT SAFETY INSTRUCTIONS PERTAINING TO A RISK OF FIRE, ELECTRIC SHOCK, OR INJURY TO PERSONS. READ AND FOLLOW ALL INSTRUCTIONS.**

Before installing this product, read and follow all warning notices and instructions which are included. Failure to follow safety warnings and instructions can result in severe injury, death, or property damage. Call (800) 831-7133 for additional free copies of these instructions.



**WARNING:** To reduce the risk of injury, do not permit children to use this product.



**WARNING: CHLORINE GAS BUILDUP CAN OCCUR WITH IMPROPER WIRING:** To reduce the risk of personal injury the IntelliChlor® Electronic Chlorine Generator (IECG) Power Supply must be installed on and wired to the load side of the time clock, electronically controlled switch, or relay load side, so that it will receive power only when the pool pump is on. Otherwise, dangerous chlorine gas buildup can occur. The IECG should never be energized when the pool pump is OFF and water is not flowing through the unit.



**WARNING:** To reduce the risk of injury, service should only be performed by a qualified pool service professional.



**WARNING:** Never operate the IntelliChlor Electronic Chlorine Generator (IECG) without proper flow or water circulation. A build-up of flammable gases will result in hazardous conditions.



**CAUTION -** IntelliChlor Electronic Chlorine Generator (IECG) is for use with permanently-installed pools and may also be used with hot tubs and spas if so marked. Do not use with storable pools. A permanently-installed pool is constructed in or on the ground or in a building such that it cannot be readily disassembled for storage. A storable pool is constructed so that it is capable of being readily disassembled for storage and reassembled to its original integrity.



**CAUTION -** The IC15 Power Supply must be interconnected with pool pump motor power source. This ensures the IECG and pool pump will switch on and off together.



**WARNING -** The IC15 Power Supply is only intended for use with the IC15 cell, DO NOT PLUG ANY OTHER INTELLICHLOR CELL INTO THIS POWER SUPPLY, SEVERE DAMAGE WILL RESULT.



**WARNING -** In order to avoid potential electrical hazard, if the supplied AC power cord is damaged, it must ONLY be replaced by the manufacturer.



**CAUTION -** When the IC15 (IECG) is installed in Europe, IC15 (IECG) power supply fuses should ONLY be obtained from the manufacturer.

# IMPORTANT SAFETY PRECAUTIONS

## SAVE THESE INSTRUCTIONS



**WARNING:** When mixing acid with water, **ALWAYS ADD ACID TO WATER. NEVER ADD WATER TO ACID.**



**CAUTION** - Use of chemicals other than those recommended may be hazardous. Even proper use of the recommended chemicals can be hazardous. Follow the Chemical Manufacturer's Instructions.



**CAUTION** - To reduce the risk of electric shock, install IntelliChlor Electronic Chlorine Generator (IECG) a minimum of five (5) feet away from the inside wall of the pool.



**CAUTION** - Install the IECG a minimum of three (3) feet away from the heater outlet.



**CAUTION** - It is recommended to install a Pentair **two (2) inch CHECK VALVE** (P/N 263042) between the input side of the IECG and the main heater output pipe.



**CAUTION** - A solid copper, bonding conductor not smaller than No. 8 AWG (8.4 mm) should be connected to all metal parts of the swimming pool, spa, or hot tub structure and to all electrical equipment, metal conduit, and metal piping within five (5) feet (1.5 m) of the inside walls of a swimming pool, spa, or hot tub, when the unit is installed within five (5) feet of the inside walls of the swimming pool, spa, or hot tub.

**Canada - Industry Canada (IC)** - This device complies with RSS210 of Industry Canada. (1999)

**FCC Standard** - 47 CFR Part 15, Subpart C (Section 15.247). This version is limited to chapter 1 to chapter 11 by specified firmware controlled in the U.S.A.

**Federal Communications Commission (FCC)** - This device complies with Part 15 of the FCC Rules. Operation is subject to the following two conditions: (1) this device may not cause interference, and (2) this device must accept any interference, including interference that may cause undesired operation of the device.

**Interference Statement** - This equipment has been tested and found to comply with the limits for a Class B digital device, pursuant to Part 15 of the FCC Rules. These limits are designed to provide reasonable protection against harmful interference in a residential installation. This equipment generates, uses and can radiate radio frequency energy and, if not installed and used in accordance with the instructions, may cause harmful interference to radio communications. However, there is no guarantee that interference will not occur in a particular installation. If this equipment does cause harmful interference to radio or television reception, which can be determined by turning the equipment off and on, the user is encouraged to try to correct the interference by one or more of the following measures:

- Reorient or relocate the receiving antenna.
- Increase the separation between the equipment and receiver.
- Connect the equipment into an outlet on a circuit different from that to which the receiver is connected.
- Consult the dealer or an experienced radio/TV technician for help.

**Note:** Modifications not expressly approved by the party responsible for FCC compliance could void the user's authority to operate the device.

## IntelliChlor® Electronic Chlorine Generator Overview

The IntelliChlor Electronic Chlorine Generator (IECG) model IC15 salt chlorinator uses a process known as electrolysis to produce chlorine gas which immediately dissolves into a solution to create Hypochlorite (a pool and spa water sanitizer) from a low concentration of salt added to the pool water. Hypochlorite kills bacteria, oxidizes organic material, and kills algae, then reverts back to salt. The IECG then reuses the salt and the process starts over again. The IntelliChlor system is comprised of the IECG and Power Center.

**⚠ CAUTION** - The IntelliChlor Electronic Chlorine Generator (IECG) is designed only to produce chlorine. The IECG does not monitor or control chlorine levels in the pool or spa water. It is the pool owner's responsibility for monitoring and maintaining free chlorine levels at the APSP recommended range of 2.0 to 4.0 parts per million (ppm). It is the pool owner's responsibility to check, on a regular basis, the free chlorine level while the pool pump is running, and adjust the IntelliChlor Electronic Chlorine Generator accordingly.

**⚠ WARNING** - Salt is an inherently corrosive material. While the levels of salt required for proper operation of the IntelliChlor Electronic Chlorine Generator are relatively low when compared to sea water and other salt solutions, placing any amount of salt in your pool increases the likelihood of corrosion or other deterioration of pool equipment and any surfaces used in and around your pool. Metal parts and certain natural and man-made surfaces are particularly susceptible to corrosion and deterioration when used in and around salt water pools. Pentair Water Pool and Spa does not represent or otherwise guarantee that the proper use of the IntelliChlor Electronic Chlorine Generator will prevent corrosion or other deterioration of pool equipment and any surfaces used in and around your pool. Consult your experienced pool professional, who should be able to advise you on the proper material selection, installation techniques for those materials, and the proper use, care and maintenance of those materials for your specific pool type and location in order to minimize the corrosion and deterioration that is inherent in and around salt water pools.

**⚠ CAUTION** - Do not operate the IECG with newly poured pool plaster or newly constructed pool, regardless of pool lining material. Severe salt damage can occur. **FOR ALL NEW POOLS** wait at least **ONE (1) MONTH** after construction and filling of pool water before operating IECG.

## Features

- Superior design combines cell and control panel as one assembly.
- Cell blades are made from a titanium metal base and coated with precious metal Ruthenium oxide.
- Cell blades are capable of producing chlorine for at least 7,500 hours, when the IECG is used properly.
- The IECG can be installed horizontally or vertically.
- Separate Power Center mounts to wall at equipment pad, for easy AC wiring.
- Electronics run cool for long, reliable life.
- Cell hour meter reports current usage to determine how many hours remain in the life of the unit.
- The IC15 produces up to 0.60 lbs. of chlorine per day.
- Salt level LED indicators show four ranges for the amount of salt in pool.
- Red and green LED indicators show system status for power, water flow, and cell status.
- MORE and LESS output buttons control how much chlorine is produced.
- BOOST cycle sets the unit to maximum chlorine output for 24 hours of pump run time.
- UL listed to UL1081 standards for swimming pool chlorinators.
- Approved NSF regulatory standards, and CE certified.

## IntelliChlor System Components

An IntelliChlor Electronic Chlorine Generator IntelliChlor system consists of one or more of the following:

- **IC 15 Cell (P/N 520888):** Designed for pools up to 15,000 U.S. gallons (56,000 cubic meters). The cell will produce the equivalent of 0.60 pounds of pure chlorine per 24 hours of continuous pool pump run time. The IC20 cell uses two terminal blades and two bi-polar blades.
- **IntelliChlor “dummy” bypass cell (P/N 520588):** For new pool start-up.

## IntelliChlor Electronic Chlorine Generator Control Panel and Cell Description

The IntelliChlor Electronic Chlorine Generator (IECG) includes a control panel with buttons and LED indicators to control the IECG and produce chlorine. The IECG measures the water temperature and salt level to produce chlorine at the defined output. If the salt level in the pool water is too low (red on salt display), the cell is turned off until salt is added to the pool. The controller has a self-cleaning cycle which reverses the cell polarity, reducing calcium buildup. This feature turns the cell on and off at regular intervals to minimize calcium and scale buildup and further maximizes cell life.

The IECG contains the control electronics and bipolar electrodes that electrically produces chlorine when energized with DC current. Chlorine is generated as pool water containing salt passes through the cell. The chlorine production can be varied by either adjusting the sanitizer output level on the control panel and/or by varying the number of hours the IECG is on each day. *The IECG automatically reverses the cell electrode blades every few hours to help clean the cell. This process does not interrupt the production of Chlorine.* The IECG also contains a mechanical flow sensor to ensure the proper amount of water is passing through the cell to allow chlorination to occur. The IECG automatically measures the water salinity and temperature and displays four (4) salinity ranges on the control panel using LED indicators. The IECG (IC15) includes a 15 ft. cord that plugs into the Power Supply.

- **Flow Sensor:** A flow sensor assures that there will always be adequate water flow through the IECG. If the IECG is not properly plumbed and/or does not receive adequate water flow, no chlorine will be produced.
- **Temperature Sensor:** To protect the IECG from operation and potential damage when the temperature of the pool water falls below 52° F,  $\pm 3^{\circ}$  F (11° C,  $\pm 1.67^{\circ}$  C), the temperature sensor switches the IECG off, and no chlorine is being produced.
- **Salt Sensor:** Two (2) salt sensor probes in the IECG are activated each time the IECG is switched on and again during every 12 hours of continuous running. At each of those times, the salt level LED indicator lights flash in a scrolling sequence for two (2) minutes to indicate that the IECG is in analysis mode. After two (2) minutes, the LED indicators lights will signal one (1) of four (4) salinity ranges. For more information, see “Salt Level Status LEDs” on page 7.

*Note: The salt sensor reading is within +/- 500 ppm accuracy.*

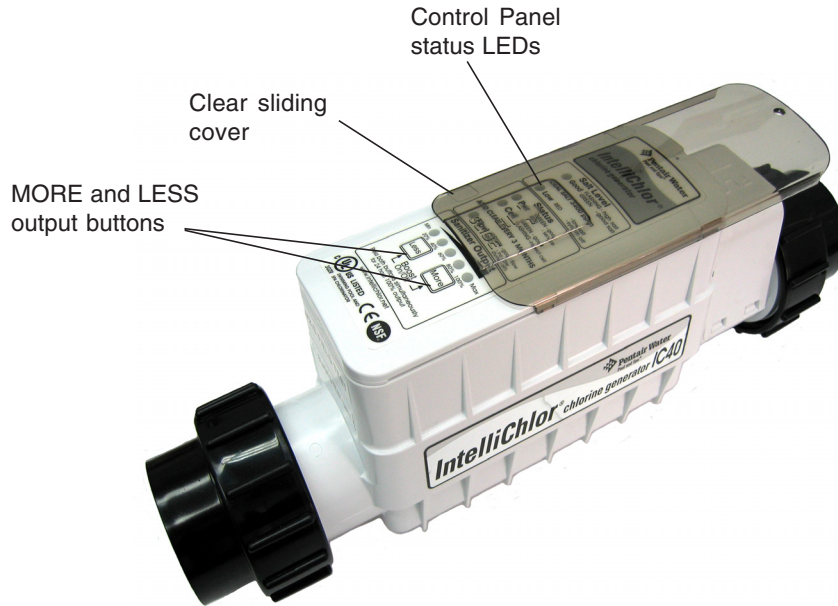

IntelliChlor Electronic Chlorine Generator (model IC15)

## IntelliChlor Power Supply

The IntelliChlor Power Supply converts AC electrical current to a low-voltage AC electrical current which is required to produce chlorine. The Power Supply is connected with the pool circulation pump electrical source so that the IECG only operates when the pool pump is on. A 15 ft. cord connected to the IC15 unit plugs into the Power Supply, which plugs directly into a 110VAC outlet. The Power Supply can be mounted vertically on the wall up to fifteen (15) feet away from the IECG. The Power Supply contains the transformer, fuse (1 AMP 250 V, 3 AG), connector to the cell and the AC electrical cord with plug. There are no other controls or lights on the Power Supply. The Power Supply must be connected to a GFCI protected outlet.

**⚠ CAUTION** - The IntelliChlor Power Supply does NOT control the pump. The IntelliChlor Electronic Chlorine Generator, model IC15 only produces chlorine when the pool pump is on.

**⚠ CAUTION** - First switch OFF AC power to the Power Supply before plugging or unplugging the IntelliChlor IC15.



IntelliChlor Power Supply



## Loop Plumbing Diagram

The IntelliChlor Electronic Chlorine Generator is designed to operate with water flow rates from 25 gallons per minute (gpm) up to 105 gpm. Do not exceed 105 gpm or pipe manufacturers recommended flow rate, whichever is less. For flow rates over 80 gpm, it is recommended that you use a bypass loop (as shown below) for best chlorine production. Installations with flow rates over 80 gallons per minute are those that have in-floor cleaning systems or booster pumps. These systems should use a bypass loop with the IECG with a flow control valve that assures that the flow through the IECG is maintained within its designed operating water flow rates.

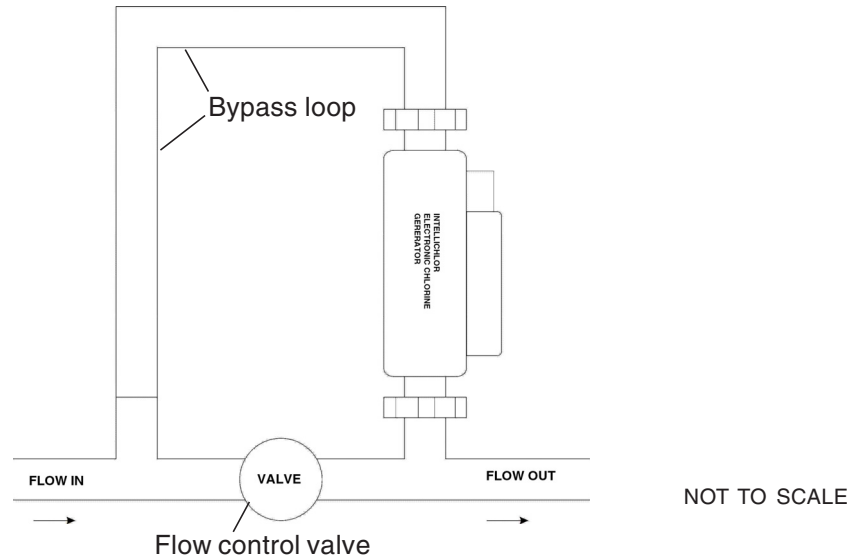

## IntelliChlor Plumbing Diagram

Plumbing the IntelliChlor Electronic Chlorine Generator (IECG):

- Always install the IntelliChlor Electronic Chlorine Generator **AFTER** the filter and heater (see “System Diagram” on page 4). The IECG should be no closer than three (3) feet away from the heater outlet.
- If the IECG is installed on a pool/spa combination system, install (see diagram below) the IECG **BEFORE** the pool/spa return valve to allow proper chlorination of both the pool and spa and also to avoid creating gas traps in the pipes.

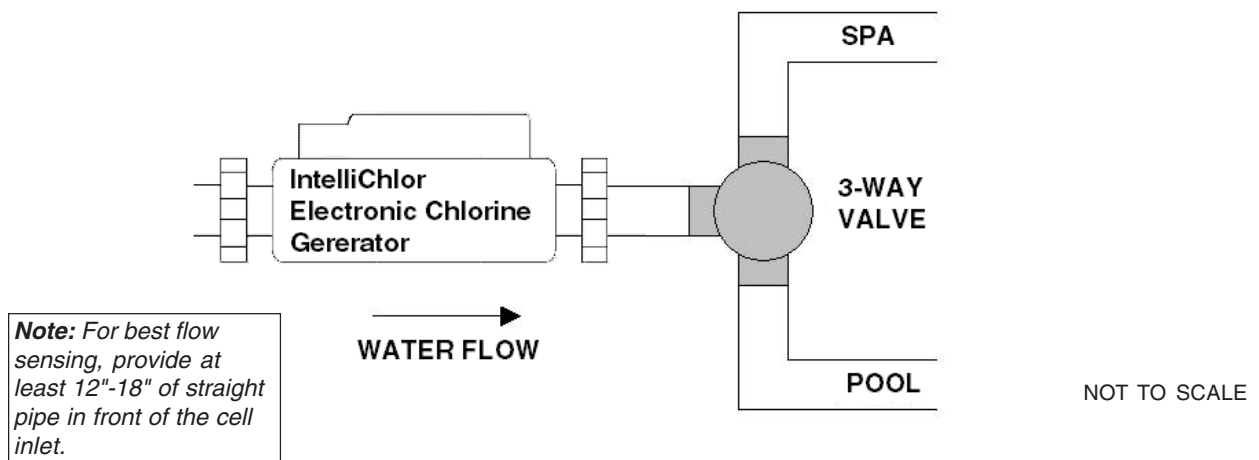

Blank Page

# Section 1

## IntelliChlor Control Panel

### Salt Level Status LEDs

The IECG salt level checks the pool water daily and displays the levels as follows:

**Green LED: Good salt.** The pool water salt level is between 2800 ppm and 4500, and the IECG is producing chlorine.

**Flashing green LED:** Salt level is above 4500 ppm. Chlorine is being produced but the salt level is too high which increases the risk of corrosion and deterioration of pool equipment and surfaces in and around the pool. Pool water needs to be drained and refilled one (1) foot at a time until the salt level is below 4500 ppm.

**Red:** Very low salt. The water salt level has fallen below 2600 ppm. The IECG will not produce chlorine until additional salt is added. The IECG is OFF.

**Flashing Red:** Low salt. The water salt level is below 2800 ppm and the LED is about to go to STEADY RED, producing no chlorine. Add salt until a green GOOD light is displayed.

### Status LEDs

**Pwr:** Shows the IntelliChlor Electronic Chlorine Generator power status:

- **Red:** An error is occurring in the IECG. Service is needed.
- **Green:** The IECG is operational and ready.

**Cell:** Shows the status of the IECG.

- **Green (flashing):** The IECG needs to be inspected. The blades may have calcium buildup. The IECG is not producing chlorine.
- **Green:** IECG is good and producing chlorine

**No Light:** IECG is off and not producing chlorine. It may be in an off-period of the sanitizing cycle and will return on shortly. This light will also be blank if the water temperature is below 52° F +/-3° F (11° C +/- 1.67° C). This cold water cutoff mode extends the blade life.

**Flow:** This light indicates the status of water flowing through the IECG.

- **Red:** Insufficient water flow through the IECG, no chlorine is being produced.
- **Green:** Sufficient water flow to produce chlorine.

**Pentair Water Pool and Spa®**  
**IntelliChlor®**  
 chlorine generator

**Salt Level**

- **Good** FLASHING - high salt  
 GREEN - good salt
- **Low** FLASHING - add salt  
 RED - low salt  
 System off

**IDEAL SALT 3400 ppm**

**Status**

- **Pwr** GREEN - good  
 RED - service
- **Cell** GREEN - good  
 FLASHING - inspect cell

**ACID CLEAN EVERY 3 MONTHS**

- **Flow** GREEN - good flow  
 RED - no flow  
 (System off)

**Sanitizer Output**

Min ● 20% ● 40% ● 60% ● 80% ● 100% Max

Less More

↑ Boost On/Off ↓

Press both buttons simultaneously for 24 hour 100% output

www.intellichlor.net

UL US LISTED CE NSF  
 30ZR SWIMMING POOL AND SPA CHLORINATOR

## Operator Control Panel (continued)

### Sanitizer Output LED Indicators

The five (5) LED indicators display as a bar graph to show in 20% increments, the percentage of time the chlorine is produced per hour of pump run time. In BOOST mode, these LEDs (blink from left to right).

*Note: If no LEDs are lit, the output is set to 0% and the IntelliChlor Electronic Chlorine Generator is not producing chlorine.*

- 0% - No LEDs lit - No chlorine produced - IntelliChlor Electronic Chlorine Generator is off.
- 20% - 1 LED lit - Produces chlorine 20% of each hour of pump run time, 12 minutes on, 48 minutes off.
- 40% - 2 LEDs lit - Produces chlorine 40% of each hour of pump run time, 24 minutes on, 36 minutes off.
- 60% - 3 LEDs lit - Produces chlorine 60% of each hour of pump run time, 36 minutes on, 24 minutes off.
- 80% - 4 LEDs lit - Produces chlorine 80% of each hour of pump run time, 48 minutes on, 12 minutes off.
- 100% - 5 LEDs lit - Produces chlorine almost 100% of each the hour of pump run time, 59 minutes on, 1 minute off.

*Note: If connected to an IntelliTouch, EasyTouch or SunTouch system, these lights may slowly flash when the output is set to a value not exactly 20%, 40%, 60% 80% or 100%. Example: 21% output setting from the IntelliTouch, EasyTouch or SunTouch will flash the 20% light.*

### More and Less Output Buttons

The More and Less buttons control the percentage of time of each hour that the IntelliChlor Electronic Chlorine Generator is producing chlorine while the pump is on (see Sanitizer Output LED indicators above). The lights act as a bar graph: the more lights that are on, the more that chlorine is produced. Slide the panel cover up to access the More, Less and Boost On/Off buttons. To exit **Boost** mode, press and hold both the **More** and **Less** buttons. *Note: When connected to an IntelliTouch, EasyTouch or SunTouch system, the Less and More buttons are disabled and IntelliChlor Sanitizer Output is controlled externally.*

**More:** Increases the time the cell produces chlorine, in 20% increments. Example: The Sanitizer Output display is showing 20%. Pressing the **MORE** button once will turn on the 40% light. The unit will produce chlorine 40% of each hour the IECG is on. Pressing **MORE** again will turn on the 60% light, and so on until all five (5) lights are on.

**Less:** Decreases the time the cell produces chlorine, in 20% increments. Example: The Sanitizer Output display is showing 40%. Pressing the **LESS** button once will turn off the 40% light, leaving only the 20% light. The unit will produce chlorine 20% of each hour the IECG is on. Pressing **LESS** again will turn off the 20% light, leaving no lights on, no chlorine is produced.

**Boost On/Off:** Press and hold both the **More** and **Less** buttons together to activate Boost mode on or off. Boost mode sets the sanitizer output to run 100% for the next 24 hours of pool pump run time. If the time clock switches off the pump cycle, then switches power back on the next day, Boost mode will continue until 24 hours has elapsed since Boost mode was turned on or Boost mode is canceled by the user. The Sanitizer Output display will show a pattern LED display to indicate Boost mode.

### Self-Cleaning

The self-cleaning feature reduces scale buildup on the blades of the IECG. The self-cleaning cycle tends to reduce the life of the IECG, therefore, it should be used only to the extent necessary to minimize the scale buildup on the blades. The self-cleaning cycle can be adjusted to run every 2, 3, 4, or 5 hours, whichever is the optimal for your particular pool conditions in order to minimize scale buildup but maximize the life of the IECG. It is factory set to two (2) hours for the first 30 days of operation, then automatically switches to three (3) hours. To change the self-cleaning cycle, press and hold the **LESS** button for three (3) seconds. The sanitizer output display will show the number of hours in a bar graph style. The number of output LEDs lit is the number of reverse hours. Pressing **More** or **Less** button will change this setting. **Example:** The self-clean cycle is set to run for four (4) hours and the pool owner chooses to change it to three (3) hours to optimize the blade cleaner cycle for your particular pool conditions. Press and hold the **LESS** button for three (3) seconds. The sanitizer output display will blank, then light up the 20%, 40%, 60% and 80% lights, four (4) total. This is a four (4) hours reverse setting. Pressing the **LESS** button once within ten (10) seconds will switch off the 80% light, leaving only three (3) lights on, now at a three (3) hours reverse setting. Wait ten (10) seconds and this mode will end automatically, returning to the original sanitizer output display.

## Section 2

# Pool Water Chemistry, Conditions and Precautions

This section describes the start up procedure and operating instructions for IntelliChlor Electronic Chlorine Generator.

### Pool Water Chemistry, Conditions and Precautions

1. **New Pool Water:** A recently filled or newly-refinished pool may contain undesirable matter. This undesirable matter could interfere with IntelliChlor's ability to chlorinate properly. Make sure the water is tested by a pool professional and properly balanced before switching on the IntelliChlor Electronic Chlorine Generator.

**▲ WARNING** - Salt is an inherently corrosive material. While the levels of salt required for proper operation of the IntelliChlor Electronic Chlorine Generator are relatively low when compared to sea water and other salt solutions, placing any amount of salt in your pool increases the likelihood of corrosion or other deterioration of pool equipment and any surfaces used in and around your pool. Metal parts and certain natural and man-made surfaces are particularly susceptible to corrosion and deterioration when used in and around salt water pools. Pentair Water Pool and Spa does not represent or otherwise guarantee that the proper use of the IntelliChlor Electronic Chlorine Generator will prevent corrosion or other deterioration of pool equipment and any surfaces used in and around your pool. Consult your experienced pool professional, who should be able to advise you on the proper material selection, installation techniques for those materials, and the proper use, care and maintenance of those materials for your specific pool type and location in order to minimize the corrosion and deterioration that is inherent in and around salt water pools.

2. **pH** produced by IntelliChlor Electronic Chlorine Generator is close to Neutral pH. However, other factors usually cause the pH of the pool water to rise. Therefore, the pH in a pool chlorinated by IntelliChlor tends to stabilize at approximately 7.8. This is within APSP standards. If the pool pH rises above 7.8, have a pool professional test the pool water to see if other factors such as high Calcium Hardness or Total Alkalinity are the cause and then balance accordingly.
3. **Super Chlorination** burns out the swimmer waste that has combined with chlorine. This frees the chlorine for sanitizing. This is accomplished by raising the chlorine level quickly and dramatically. When the chlorine level is raised to ten (10) times the amount of combined chlorine (usually 5 to 10 ppm) the pool water is said to have been super chlorinated. As pool water is continuously passed through the IECG while the unit is powered on, all pool water inside the IECG is being super chlorinated. When the IntelliChlor Electronic Chlorine Generator is used on pools, the pool water sparkles and does not burn the eyes because of the absence of chloramines.  
*Note: On initial start-up of a pool, it is best to super chlorinate using an outside source, i.e., use a shock treatment available at your local pool supplier.*
4. **Chloramines** should not be present in pool water. Chloramines are formed when ammonia (which is found in urine and sweat) combine with free chlorine. This ties up the free chlorine in your pool and does not allow the chlorine in your pool to disinfect. Chloramines also burn the eyes and are foul smelling. Super Chlorinate to remove chloramines at the initial start-up of the pool and as needed to maintain proper levels of free chlorine.
5. **Cyanuric acid** is needed in outdoor pools to help to stabilize and maintain proper levels of chlorine. 90% of unstabilized chlorine is destroyed by the UV radiation from the sun within two hours. Cyanuric acid stabilizes chlorine in water from UV degradation. When using the IECG, the cyanuric acid level should be maintained between 50-80 ppm. See Table 3, on page 14. **NOTE: DO NOT USE CYANURIC ACID IN INDOOR POOLS.**

6. **Total Dissolved Solids (TDS):** Adding salt to pool water will raise the TDS level. While this does not adversely affect the pool water chemistry or clarity, the pool water professional testing for TDS must be made aware salt has been added to the IntelliChlor system. The individual performing the TDS test (see page 22) may then subtract the salinity level to arrive at a TDS level that would be compatible to a TDS reading for a non-salt water pool.
7. **Metals** - Some metals, i.e. copper and iron, can cause loss of chlorine. Also, metals can stain your pool. Metals can also damage the IntelliChlor Electronic Chlorine Generator. Have your local pool professional check for metals and recommend methods of removal.
8. **Nitrates and Phosphates** can cause extremely high chlorine demands and will deplete chlorine from your swimming pool. In some cases nitrates may even lower your chlorine levels to zero. Your local pool professional can test for nitrates and phosphates. While a 0 ppm level of nitrates is the ideal, the pool owner should make sure that nitrates **DO NOT** exceed 10 ppm. Phosphates should not exceed 125 parts per billion (ppb).

## Optimum Pool Water Chemistry Conditions for Salt Water Pools (using the IntelliChlor Electronic Chlorine Generator)

In accordance with the Association of Pool and Spa Professionals (APSP) standards, it is recommended that the following pool water chemistry conditions be maintained on an on going basis to help protect pool users, pool related equipment and surfaces in and around the pool. These values are important to maintaining the pool equipment in proper operating condition and preventing corrosion, liming or other problems. The IntelliChlor Electronic Chlorine Generator is warranted to operate properly only if these conditions are met. For more information, refer to your local agency having jurisdiction, NSPI (National Spa and Pool Institute), the CDC (Centers for Disease Control), or the WHO (World Health Organization).

<b>Free Chlorine:</b>	2.0 - 4.0 ppm. Above 4.0 ppm may cause corrosion of metal components
<b>Combined Chlorine (Chloramines):</b>	None (super chlorinate to remove all chloramines)
<b>pH:</b>	7.2 - 7.8 (USE MURIATIC ACID to lower pH and Soda Ash to raise pH.)
<b>Cyanuric Acid:</b>	50 - 80 ppm
<b>Total Alkalinity:</b>	80 - 120 ppm
<b>Calcium Hardness:</b>	200 - 400 ppm
<b>TDS (includes salt):</b>	3000 minimum to 5700 to 6000 maximum ppm
<b>Salt:</b>	3000 - 4500 ppm (ideal 3400 ppm)
<b>Metals (Copper, Iron, Manganese):</b>	None
<b>Nitrates:</b>	None
<b>Phosphates:</b>	Less than 125 ppb

## Covered Pools and Vinyl Liner Pool and Lowering Chlorine Output Levels

When using the IntelliChlor Electronic Chlorine Generator with covered pools and/or vinyl liner pools, less chlorine is needed. It is recommend to lower the chlorine output level while the pool is covered. For more information about chlorine output levels, see “More or Less Output Buttons” page 8.

## Chlorine Testing

It is recommended that chlorine test samples be taken from two (2) locations in the pool. Compare the samples. A higher level should be found at the pool return line. The higher level at the pool return line indicates the IECG is producing chlorine. Take chlorine samples for testing at:

- The pool return line.
- 18 inches (457 mm) below the surface and well away from the pool return line.

## What Type of Salt to Use

The purer the salt, the better the life and performance of the IntelliChlor Electronic Chlorine Generator. Use salt that is at least 99.8% pure NaCl, sodium chloride. The preferred and recommended salt is an evaporated, granulated, food quality, non-iodized salt with no additives. Consult your salt supplier.

- Avoid using salt with anti-caking agents (sodium ferrocyanide, also known as YPS or yellow prussiate of soda). Filling agents can cause some discoloration of fittings and surface finishes in pool.
- Water conditioning salt pellets are compressed forms of evaporated salt and may be used, but will take longer to dissolve. Such pellets could damage pool plaster and other surfaces in and around the pool.
- Do not use calcium chloride or potassium chloride as a source of salt. (Use sodium chloride only).
- Do not use Rock salt (insoluble impurities mixed with the rock salt can shorten the life of the IECG).

## How Much Salt to Use?

 **CAUTION** - Do not operate the IECG with newly poured pool plaster or a newly constructed pool, regardless of pool lining material. Severe salt damage can occur. **FOR ALL NEW POOLS**, wait at least **ONE (1) MONTH** after construction and filling of pool water before operating the IECG.

Use the Table 1 chart (page 13) to determine how much salt will be needed. Most pools contain some salt, depending on the water source and chemicals used for sanitizing. Therefore, the pool owner must always test salt levels before adding salt. A hand held meter calibrated for NaCl (salt) can be used to determine the salt levels of the pool water. After the IntelliChlor Electronic Chlorine Generator is powered on, the LED salt level lights will blink from bottom to top for two (2) minutes while it analyzes the pool water, then the LED indicators will show one (1) of four (4) salt level ranges. This solid light indicates the salt status of the pool.

- 3000 to 3500 ppm of salt is recommended for optimum water conditions.
- Low salt concentration below 2600 ppm will cause the unit to turn off
- High salt concentration above 4500 ppm may cause excessive corrosion or deterioration to pool equipment and surrounding surfaces in and around the pool.

*Note: Salt measurements will vary between measuring devices (salt test strips, electronic testers, and titration). The salt sensor reading is within +/- 500 ppm accuracy. For more troubleshooting information about high salt levels, see "Troubleshooting," on page 33.*

## Calculating the Saturation Index

The saturation index is a formula that relates pH, calcium and alkalinity in the pool water. A well balanced pool water will have a formula result range between -0.3 and 0.3. Outside this range, the pool water is out of balance, potentially damaging pool equipment or scaling the IECC. The equation to calculate Si is:

$$SI = pH + CHF + AF + TF + TDSF$$

Saturation Index	pH as tested	Calcium Hardness Factor	Alkalinity Factor	Tempera- ture Factor	TDS Factor
---------------------	-----------------	-------------------------------	----------------------	----------------------------	---------------

Cyanuric acid in the form of cyanurate ions contribute to alkalinity. Thus, a correction must be made to total alkalinity. We subtract 1/3 of the cyanuric acid level from the reading obtained in the total alkalinity test.

$$\text{Total Alkalinity} - \frac{1}{3} \text{Cyanuric Acid} = \text{Corrected Alkalinity}$$

This correction can be considerable in established pools with high cyanuric acid levels; for example, at 240 ppm cyanuric acid, the correction amounts to 80 ppm (240 ÷ 3 = 80).

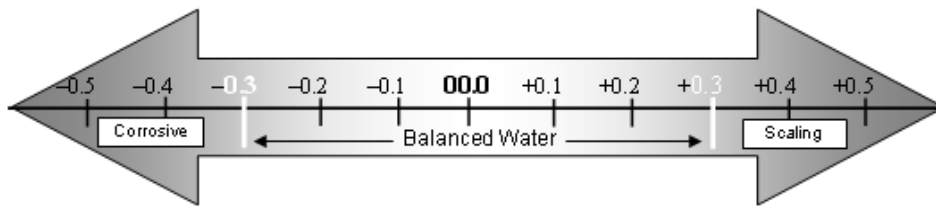

## Saturation Index Factors

Table 1 – CHF and AF Hardness and Alkalinity Factors		Table 2 – TF Temperature Factors		Table 3 – C TDS Factors	
Calcium Hardness and Alkalinity (ppm)	Factor	Temperature Degrees F	Factor	TDS (ppm)	Factor
25	1.4	32	0.0	500	-12.20
30	1.5	42	.1	1000	-12.29
50	1.6	55	.2	1500	-12.34
65	1.7	67	.3	2000	-12.39
75	1.8	79	.4	2500	-12.42
100	1.9	91	.5	3000	-12.45
125	2.0	103	.6	3500	-12.48
150	2.1	115	.7	4000	-12.50
200	2.2			4500	-12.52
250	2.3			5000	-12.53
300	2.4				
400	2.5				
500	2.7				
600	2.8				

## How to Add Salt to the Pool

**⚠ CAUTION** - Do not operate the IECG with newly poured pool plaster or a newly constructed pool, regardless of pool lining material. Severe salt damage can occur. **FOR ALL NEW POOLS**, wait at least **ONE (1) MONTH** after construction and filling of pool water before operating IECG.

1. Switch on the pump to circulate the pool water.
2. Check salt level in pool water before adding any salt to pool.
3. Determine the amount of salt from the following charts.
4. Slowly pour in the salt around the outer perimeter of the pool for quick and even distribution. *To avoid clogging the filter or damaging pool related equipment and surrounding surfaces, do not add salt through the skimmer or surge tank.*
5. Brush the pool bottom and allow water to circulate for 24 hours to dissolve salt completely.
6. After 24 hours, verify correct salt level reading by checking the LED indicators on the IntelliChlor Electronic Chlorine Generator and by a separate reliable test method.
7. Power on the IntelliChlor Electronic Chlorine Generator and set the Sanitizer Output level to the proper setting to maintain the appropriate free chlorine levels in the pool water (i.e., within the 2.0 - 4.0 ppm, APSP recommended range).

**Table 1.** Approximate Pounds (Kg) of salt needed to obtain 3,400 ppm in pool

CHART FOR ADDITION OF SALT TO 3400 PPM											
Pool Gallons	0 ppm	250 ppm	500 ppm	750 ppm	1000 ppm	1250 ppm	1500 ppm	1750 ppm	2000 ppm	2250 ppm	2500 ppm
10,000	290 lb	267 lb	244 lb	221 lb	191 lb	168lb	145 lb	122 lb	99 lb	70 lb	46 lb
	132 kg	121 kg	111 kg	100 kg	87 kg	76 kg	66 kg	55 kg	45 kg	32 kg	21 kg
12,000	348 lb	320 lb	292 lb	265 lb	230 lb	202 lb	174 lb	146 lb	118 lb	84 lb	56 lb
	158 kg	145 kg	133 kg	120 kg	104 kg	92 kg	79 kg	66 kg	54 kg	38 kg	25 kg
14,000	406 lb	374 lb	341 lb	309 lb	268 lb	236 lb	203 lb	171lb	138 lb	97 lb	65 lb
	184 kg	170 kg	155 kg	140 kg	122 kg	107 kg	92 kg	77 kg	63 kg	44 kg	29 kg
16,000	464 lb	427 lb	390 lb	353 lb	306 lb	269 lb	232 lb	195 lb	158 lb	111 lb	74 lb
	211 kg	194 kg	177 kg	160 kg	139 kg	122 kg	105 kg	88 kg	72 kg	51 kg	34 kg
18,000	522 lb	480 lb	439 lb	397 lb	345 lb	303 lb	261 lb	219 lb	178 lb	125 lb	84 lb
	237 kg	218 kg	199 kg	180 kg	156 kg	137 kg	118 kg	99 kg	81 kg	57 kg	38 kg
20,000	580 lb	534 lb	487 lb	441 lb	383 lb	337 lb	290 lb	244 lb	197 lb	139 lb	93 lb
	263 kg	242 kg	221 kg	200 kg	174 kg	153 kg	132 kg	111 kg	89 kg	63 kg	42 kg
22,000	638 lb	587 lb	536 lb	485 lb	421 lb	370 lb	319 lb	268 lb	217 lb	153 lb	102 lb
	290 kg	266 kg	243 kg	220 kg	191 kg	168 kg	145 kg	122 kg	98 kg	69 kg	46 kg
24,000	696 lb	641 lb	585 lb	529 lb	460 lb	404 lb	348 lb	292 lb	237 lb	167 lb	111 lb
	316 kg	291 kg	265 kg	240 kg	208 kg	183 kg	158 kg	133 kg	107 kg	76 kg	51 kg
26,000	754 lb	694 lb	634 lb	573 lb	498 lb	438 lb	377 lb	317 lb	256 lb	181 lb	121 lb
	342 kg	315 kg	287 kg	260 kg	226 kg	198 kg	171 kg	144 kg	116 kg	82 kg	55 kg
28,000	812 lb	747 lb	682 lb	617 lb	536 lb	471 lb	406 lb	341 lb	276 lb	195 lb	130 lb
	368 kg	339 kg	310 kg	280 kg	243 kg	214 kg	184 kg	155 kg	125 kg	88 kg	59 kg
30,000	870 lb	801 lb	731 lb	662 lb	574 lb	505 lb	435 lb	366 lb	296 lb	209 lb	139 lb
	395 kg	363 kg	332 kg	300 kg	261 kg	229 kg	197 kg	166 kg	134 kg	95 kg	63 kg

**Table 2.** Approximate Pounds (Kg) of salt needed to maintain 3,400 ppm in pool

Salt concentration before addition	Salt addition required per 1000 gallon (3,800 liters) pool capacity	Salt concentration before addition	Salt addition required per 1000 gallon (3,800 liters) pool capacity
0 ppm	29 lbs (13 kg)	1500 ppm	15 lbs (15 kg)
250 ppm	27 lbs (12 kg)	1750 ppm	12 lbs (5 kg)
500 ppm	24 lbs (11 kg)	2000 ppm	10 lbs (5 kg)
750 ppm	22 lbs (10 kg)	2250 ppm	7 lbs (3 kg)
1000 ppm	19 lbs (9 kg)	2500 ppm	5 lbs (2 kg)
1250 ppm	17 lbs (8 kg)	2800 ppm	3 lbs (1.4 kg)

**Table 3.** Approximate amount of cyanuric acid to obtain 75 ppm in pool

Stabilizer Level Before Addition	Pool Size in gallons (liters)										
	10,000 (38,000)	12,000 (45,000)	14,000 (53,000)	16,000 (60,000)	18,000 (68,000)	20,000 (76,000)	22,000 (83,000)	24,000 (91,000)	26,000 (98,000)	28,000 (106,000)	30,000 (113,000)
0 ppm	6.25 lbs (2.8 kg)	7.50 lbs (3.4 kg)	8.75 lbs (4 kg)	10.0 lbs (4.5 kg)	11.25 lbs (5 kg)	12.5 lbs (5.7 kg)	13.75 lbs (6.2 kg)	15.0 lbs (6.8 kg)	16.3 lbs (7.4 kg)	17.5 lbs (7.9 kg)	18.75 lbs (8.5 kg)
10 ppm	5.40 lbs (2.5 kg)	6.50 lbs (2.9 kg)	7.60 lbs (3.5 kg)	8.60 lbs (3.9 kg)	9.75 lbs (4.4 kg)	10.8 lbs (5 kg)	11.90 lbs (5.4 kg)	12.9 lbs (5.8 kg)	14.0 lbs (6.3 kg)	15.2 lbs (6.9 kg)	16.25 lbs (7.4 kg)
20 ppm	4.60 lbs (2 kg)	5.50 lbs (2.5 kg)	6.40 lbs (2.9 kg)	7.30 lbs (3.3 kg)	8.25 lbs (3.7 kg)	9.20 lbs (4.1 kg)	10.0 lbs (4.5 kg)	10.9 lbs (4.9 kg)	11.9 lbs (5.4 kg)	12.8 lbs (5.8 kg)	13.75 lbs (6.2 kg)
30 ppm	3.75 lbs (1.7 kg)	4.50 lbs (2 kg)	5.25 lbs (2.4 kg)	6.00 lbs (2.7 kg)	6.75 lbs (3 kg)	7.50 lbs (3.4 kg)	8.25 lbs (3.7 kg)	9.00 lbs (4 kg)	9.75 lbs (4.4 kg)	10.5 lbs (4.8 kg)	11.75 lbs (5.3 kg)
40 ppm	2.90 lbs (1.3 kg)	3.50 lbs (1.6 kg)	4.00 lbs (1.8 kg)	4.60 lbs (2 kg)	5.25 lbs (2.4 kg)	5.80 lbs (2.6 kg)	6.40 lbs (2.9 kg)	6.90 lbs (3.1 kg)	7.58 lbs (3.4 kg)	8.20 lbs (3.7 kg)	8.75 lbs (4 kg)
50 ppm	2.00 lbs (1 kg)	2.50 lbs (1.1 kg)	2.90 lbs (1.3 kg)	3.30 lbs (1.5 kg)	3.75 lbs (1.7 kg)	4.10 lbs (1.9 kg)	4.60 lbs (2 kg)	4.90 lbs (2.2 kg)	5.40 lbs (2.4 kg)	5.80 lbs (2.6 kg)	6.25 lbs (2.8 kg)
60 ppm	1.25 lbs (0.5 kg)	1.50 lbs (0.7 kg)	1.75 lbs (0.8 kg)	2.00 lbs (1 kg)	2.25 lbs (1 kg)	2.50 lbs (1.1 kg)	2.75 lbs (1.2 kg)	3.00 lbs (1.4 kg)	3.25 lbs (1.5 kg)	3.50 lbs (1.6 kg)	3.75 lbs (1.7 kg)
70 ppm	0.40 lbs (0.2 kg)	0.50 lbs (0.2 kg)	0.60 lbs (0.3 kg)	0.66 lbs (0.3 kg)	0.75 lbs (0.3 kg)	0.80 lbs (0.4 kg)	0.90 lbs (0.4 kg)	1.00 lbs (0.4 kg)	1.10 lbs (0.5 kg)	1.20 lbs (0.5 kg)	1.25 lbs (0.6 kg)
75 ppm	0.0 lbs (0 kg)	0.0 lbs (0 kg)	0.0 lbs (0 kg)	0.0 lbs (0 kg)	0.0 lbs (0 kg)	0.0 lbs (0 kg)	0.0 lbs (0 kg)	0.0 lbs (0 kg)	0.0 lbs (0 kg)	0.0 lbs (0 kg)	0.0 lbs (0 kg)

**NOTE:** The cyanuric acid reading should be maintained at 50 - 80 ppm.

## Pool Water Preparation

### Determining Pool Size (Gallons of Water in Your Pool)

- **Rectangular Pools:** Length x width x average depth x 7.5
- **Circular Pools:** Diameter x diameter x average depth x 5.9
- **Oval Pools:** Length x width x average depth x 6.7
- **Sloping Sides:** Multiply total gallons by 0.85 = gallon capacity

### Determining Pool Size (liters of water in your pool)

- **Rectangular Pools:** Length x width (meters) x average depth x 1000
- **Circular Pools:** Diameter x diameter x average depth x 785
- **Oval Pools:** Length x width (meters) x average depth x 893
- **Sloping Sides:** Multiply total liters by 0.85 = liter capacity.



**CAUTION** - Never use dry acid (sodium bisulfate) to adjust pH in arid geographic areas with excessive evaporation and minimal dilution of pool water with fresh water. A buildup of byproducts can damage the IECG.

Blank Page

# Section 3

## Operating IntelliChlor

This section describes the start up procedure and operating instructions for IntelliChlor Electronic Chlorine Generator (IECG).

Before starting up and operating the IECG, the pool in which the IECG will be used must have been completed and filled with water for at least one (1) month and the pool water salt level must be stable and being maintained at 3,200 to 3,500 ppm.

### Initial Start up Period

For the first thirty (30) days of cell operation, the self-cleaning cycle, is factory set to two (2) hours. After thirty (30) days has elapsed, the IECG will automatically set itself to three (3) hour self-cleaning cycle. This feature will clean the IECG blades more often during the initial installation, then go to a more standard self-cleaning cycle for longer blade life.

### Operation

#### Use of an external Pool Pump Timer is not required

The IECG is designed to supply a sufficient amount of chlorine to sanitize pool water on a daily basis. If the pool pump is continuously running and the IECG is operated 24 hours a day at 100%, more chlorine would be generated than would be needed by most pools (2-4 ppm, per APSP recommendations). The IECG has its own internal timer which cycles the electrolytic cell on and off depending on what percent the Sanitizer Output is set. For instance, at 100% the cell works all the time while the pool pump is running. When set at 80%, the cell is allowed to rest 20% of the time while the pool pump is running prolonging cell life. In order to fine tune IECG to your pool size just increase or decrease the Sanitizer Output from 20% to 100% of the time. For more information, see “More and Less Output Buttons,” on page 8.

**⚠ CAUTION** - The IECG is designed only to produce chlorine. The IECG does not monitor or control chlorine levels in the pool or spa water. It is the pool owner's responsibility for monitoring and maintaining free chlorine levels at 2.0 to 4.0 parts per million (ppm) according to APSP recommendations. It is the pool owner's responsibility to check the free chlorine level while the pool pump is running on a regular basis, and adjust the Sanitizer Output on the IECG accordingly.

**⚠ CAUTION** - Before attempting to operate IntelliChlor refer to “General Recommendations and General Cautions,” on page 19, and “Pool Water Preparation,” on page 15. Also, do not adjust Sanitizer Output above 20% until it is certain that salt has been dissolved in pool. Operating without salt will result in the unit turning off and lighting the ADD SALT light on the salt display. No chlorine will be produced until salt is added to the pool.

#### If you use a Pool Pump Timer

The Association of Pool and Spa Professionals (APSP) recommends that all water in a residential pool pass through the filtration system at least once every twelve (12) hours (referred to as pool water turnover). However, many factors have an effect on actual pump and filter system run times. Pool size, source of water, direct sun light, indoor/outdoor, screened/unscreened, filtration system, cold or hot weather, swimmer load, rain, organic debris, algae, etc., are all factors which contribute to either more or less pool pump and filter system run times. Because of these differences, it is extremely difficult to set a standard initial run time (starting point) for the pool pump and chlorinating system.

Try initially setting the pool pump timer to twelve (12) hours. It will take a few days to achieve the correct amount of pool pump operating time. When IntelliChlor is wired with a pool pump timer **results will vary greatly from one pool installation to the next, so this should be discussed with your pool professional. The key points are:**

- Operate the pool pump at least the minimum time needed for good filtration and adequate chlorine production by the IECG, according to your pool professional's recommendations.
- While pool pump timers can reduce energy consumption, the pool pump must be running for the IntelliChlor Electronic Chlorine Generator to provide chlorine and must remain running long enough to maintain proper chlorine levels (i.e., 2.0 - 4.0 ppm of free available chlorine).

*Note: Exception - For Cold Weather Operation: The unit turns off in water temperatures of 52° F, ±3° F (11° C, ±1.67° C) and below, and will not produce chlorine. This feature extends the life of the cell.*

## Start-up Procedure (Super Chlorination)

**Super Chlorination is recommended before pool start-up.** Start out with clean, properly chlorinated, pool water from the beginning. The IECG will build up a sufficient level of chlorine for sanitation in several hours. However, if the pool water has a high demand from the start-up the IECG will not be able to produce enough chlorine to reach break-point chlorination. So, it is best to super chlorinate using an outside source at the time of pool start-up. Then, wait until the chlorine level has returned to 2.0 to 4.0 ppm before switching on the IECG.

## Sanitizer Output Settings and Adjustments

- Switch on the pool pump switch or pool pump timer. The IntelliChlor control panel green PWR power LED light should be on. The salt display will blink both LEDs (bottom to top) for two (2) minutes, indicating that it has not checked the salt level yet. After two (2) minutes, the salt will be checked and one (1) of the four (4) salt level LEDs will be displayed. If the salinity is below 2600 ppm, the salt display will light the red LOW SALT indicator, and the CELL light will go blank, indicating there is not enough salt in the pool for chlorine to be produced.
- Set the Sanitizer Output to 60% by pressing the **MORE** or **LESS** button (see page 8).
- After 24 hours, use a reliable test method to test the pool water for free available chlorine. The ideal range to maintain is 2.0-4.0 ppm. **If the free chlorine level of the pool water is too low, increase chlorine production by pressing the MORE button. If the free chlorine level of the pool water is too high, decrease chlorine production by pressing the LESS button.**
- Due to a varying free chlorine demand of pool water, it may take a few days to determine the number of daily pool operating hours and "Sanitizer Output" percentage setting (see page 8) for your pool. Continue adjusting as necessary, allowing 24 hours between adjustments until the free chlorine level of the pool water is stabilized at 2.0 - 4.0 ppm, per APSP recommendations.

## Operating in Winter

The IntelliChlor Electronic Chlorine Generator switches off and will not produce chlorine in water temperatures of 52° F, ±3° F (11° C, ±1.67° C) and below. This feature extends the life of the IECG. See "Winterizing," on page 23.

## General Recommendations

- After new pool construction has been completed, before installing the IntelliChlor Electronic Chlorine Generator, install the IntelliChlor “dummy cell” (P/N 520588) to remove debris from the pipes for thirty (30) days and to allow sufficient time for the pool plaster (or other similar material) to properly cure and seal.
- Read and keep this Installation and User’s Guide in a safe place.
- Increase Sanitizer Output level as necessary after heavy rain (outdoor pools) and return to normal afterwards.
- Increase Sanitizer Output level when air and water temperature rise.
- Increase Sanitizer Output level when number of pool users increase.
- Use Cyanuric Acid ONLY as necessary to stabilize chlorine in the pool water in outdoor pools.  
NOTE: DO NOT USE CYANURIC ACID IN INDOOR POOLS.
- Once a month take a pool water sample to a pool professional for a complete analysis.

## General Cautions

- Do not get fertilizer in your pool. Fertilizers contain nitrates, which cause a high chlorine demand.
- Never use dry acid to adjust pH in arid geographic areas with excessive evaporation and minimal dilution of pool water with fresh water. A buildup of byproducts can damage the IECG.
- Do not add any pool water balancing chemicals (including salt) unless the IECG is switched off.
- Do not let the Cyanuric Acid level drop below 50 ppm in outdoor pools. NOTE: DO NOT USE CYANURIC ACID IN INDOOR POOLS.

Blank Page

# Section 4

---

## User Maintenance

This section describes how to maintain the IntelliChlor Electronic Chlorine Generator.

### Daily service

None is needed.

### Weekly service

1. **pH Level Test:** Test the pH level of your pool water with a reliable test method. If necessary, adjust according to your pool professional's recommendations. APSP's recommended ideal range for pH is 7.4 to 7.6, although 7.2 to 7.8 is an acceptable range under APSP's guidelines.

*Note: Never use dry acid (sodium bisulfate) to adjust pH in arid geographic areas with excessive evaporation and minimal dilution of pool water with fresh water. A buildup of byproducts can damage the IECCG.*

2. **Total Alkalinity Test:** Test the pool water for total alkalinity with a reliable test method. Adjust according to your pool professional's recommendations. APSP's recommended ideal range for total alkalinity is 80 to 120 ppm.
3. **Chlorine Test:** Test the pool water the free chlorine level with a reliable test method. Maintain ideal range by adjusting the IntelliChlor Electronic Chlorine Generator Sanitize Output settings. See "More and Less Output Buttons," on page 8.
  - Defined Free Chlorine is 2.0-4.0 ppm, per APSP recommendations.

*Note: Above 4.0 ppm of chlorine may cause excessive corrosion of metal components and possibly cause damage to associated pool equipment.*

*Note: It is recommended that free chlorine readings be taken from samples of pool water taken from two (2) places, one at the pool return line, the other well away from the pool return line. Compare the test results. A higher free chlorine level should be found at the pool return line. The higher free chlorine level at the pool return line indicates IntelliChlor Electronic Chlorine Generator is producing chlorine.*

### Monthly Service

To ensure that the correct chemical balance is maintained in your pool, it is important to perform the following recommended salt and pool water tests every month using a reliable test method.

1. **Salt Level Test:** Check salt display lights on the unit and check that the green "GOOD" light is on and is not flashing.
  - If the red LOW LED salt light is on, no chlorine is being produced. Add salt to the pool water (see charts beginning on page 13).
  - If salt level does not rise after 24 hours, see "Troubleshooting," page 33.
2. **Pool Water Sample:** Take a sample of the pool water to your local pool store for testing.

## Monthly Service (Continued)

3. **Cyanuric Acid:** Sample the pool water and test for cyanuric acid level using a reliable test method. When using the IntelliChlor Electronic Chlorine Generator the recommended ideal cyanuric acid level is 50-80 ppm.
4. **Calcium Hardness:** Test pool water for calcium hardness level using a reliable test method. If necessary, adjust according to your pool professional's recommendations. APSP's recommended ideal range for calcium is 200 to 400 ppm for pools.
5. **Metals Test:** It is recommended that the pool water be sampled and tested periodically for the presence of metals such as copper, iron, and manganese. These metals can damage the IntelliChlor Electronic Chlorine Generator and other related pool equipment and should not be present in the pool water. If those metals are present, contact your pool professional.
6. **TDS (Total Dissolved Solids):** Test pool water for TDS level using test kit or by having a water sample tested by a pool professional. If necessary, adjust according to your pool professional's recommendations. APSP standard of 3000 minimum to 5700 - 6000 maximum ppm (which includes the salt) is recommended for salt pools.

## IECG Usage Hours Meter

The IECG provides a built-in cell "usage hours" meter that reports how many hours IntelliChlor has been operating. The IECG is designed to operate for approximately 8,000 hours before replacement is needed or roughly five (5) years of average use.

To access the system status mode:

1. Press and hold the **MORE** button for three (3) seconds until the lights scroll across the unit.
2. One (1) of the five (5) Sanitizer Output LED indicators (20%, 40%, 60%, 80% and 100%) will be lit, indicating the hours of usage. The Output LEDs are as follows:
  - 2000 hours (20% LED on)
  - 4000 hours (40% LED on)
  - 6000 hours (60% LED on)
  - 8000 hours (80% LED on)
  - 10,000 hours (100% LED on)

## Cleaning the IECG Cell Blades

1. **Automatic Cleaning:** The IECG has an automatic cell blade cleaning feature (cell reversing) helps remove scale deposits from the IECG blades. **Note:** Automatic cleaning does not interrupt chlorine production. "Scale" is a white crusty deposit that forms in excessively hard water or from pool water that is out of balance and in a scaling condition. If the IECG blades show excessive scaling, you need to perform an acid wash cleaning. Proceed to "Acid Wash Cleaning," Step 2.
2. **Acid Wash Cleaning:** If the IECG blades show a tendency to scale, it is recommended that every two (2) months the IECG be removed and inspected for scale formation and/or debris on the IECG blades. Some filters allow debris to pass through to the IECG, possibly lodging between the blades in the IECG. A small amount of scale formation is normal. If by looking through the IECG it is observed that there is excessive scale formation between the blades or debris is present, the IECG must be cleaned as follows:
  - a. Use a high-pressure jet of water from a garden hose. If the blades cannot be reasonably cleaned in this manner, acid cleaning is necessary.

## Cleaning the IECG Blades (Continued)

- b. **To acid clean the IECG blades:** Disconnect the AC power from the Power Center. Disconnect the IntelliChlor Electronic Chlorine Generator cell communication cable from the Power Center.
- c. Mix one (1) quart of muriatic acid with one (1) gallon of tap water in a plastic bucket.



**WARNING**

Working with muriatic acid can be dangerous. When cleaning the IECG always wear rubber gloves and eye protection. Always add acid to water, do not add water to acid. Always work in a well-ventilated area. Splashing or spilling acid can cause severe personal injury and/or property damage.

*Note: The IntelliChlor acid cleaning kit (P/N 520710) provides a cap for the IECG to allow diluted acid solution to be poured into the IECG to immerse the blades for cleaning.*

- d. Screw the cap with washer and o-ring onto the threaded end of the IntelliChlor cell (*the cap, o-ring and washer are provided with the cleaning kit*). Place the IECG vertically in a five (5) gallon bucket. Pour the acid solution (as described in step c) into the IECG until the cell blades are just covered. Allow the acid solution to bubble, and to clean the blades. **Note: The acid should only be contained inside the IECG covering the blades. Try not to spill the acid on the outside of the IECG. If acid does spill on the outside of the IECG, wash it off with water.** A foaming action will begin, which is caused by scale (calcium carbonate) being dissolved from the blades. If rigorous foaming action does not begin, the blades do not need to be cleaned (**STOP THE CLEANING PROCESS - go on to step “e”**). **Otherwise, allow the blades to remain immersed in the solution until the foaming has stopped. However, do not leave acid in the IECG for more than thirty (30) minutes. Excessive acid washing will damage the blades.**
- e. Remove the IECG from the bucket and place in an empty five (5) gallon bucket. Rinse the inside and outside of the IECG thoroughly with clean tap water and inspect. If deposits are still visible, repeat the acid cleaning process.
- f. Rinse the IECG again with clean tap water and inspect. Once clean, replace the IECG and resume normal operation.
- g. If the acid wash procedure is necessary, it is recommended that a sample of pool water be analyzed by a pool professional for excessive calcium hardness (i.e. ideal range is 200 to 400 ppm) and/or improper water balance.
- h. **Inspect the inside of the IECG every two (2) months.** If no scale or debris deposits are observed inside the IECG after four (4) months, it is not necessary to continue inspections every two (2) months. However, due to possible changes in pool water chemistry and filtering effectiveness, it is recommended that the cell be removed for inspection at least twice a year.
- i. Reconnect the IECG communication cable plug in the Power Center, then reconnect AC power to the IntelliChlor Power Center.

## Winterizing

Very little chlorine production is needed in cold water so long as free chlorine levels are maintained at 2.0 - 4.0 ppm. The IntelliChlor Electronic Chlorine Generator will not produce chlorine below 52° F ±3° F (11° C, ±1.67° C). This low-temperature cutoff extends the life of the cell. If preventative measures are not taken, freezing water may cause severe damage to the cell. Prevent freeze damage to the cell by running the pool pump continuously or winterize the pool by draining water from pump, filter, and all intake and return lines. Remove the cell, clean and store it.

Blank Page

# Section 5

## Installation

This section describes how to install the IntelliChlor Electronic Chlorine Generator into the pool plumbing system. Before installing, review the IntelliChlor IC15 kit contents and required tools.

*Note: Salt is not provided.* For details about the type of salt to use, see “What Type of Salt to Use,” on page 11.

### Kit Contents

- One IntelliChlor Electronic Chlorine Generator (IC15)
- Two (2) 1.25 inch adapters
- One (1) Power Supply
- User's Guide (this manual)

### Required Tools

- Tape measure
- Phillips and flathead screwdriver
- Pliers
- Hacksaw
- An NSF® approved all purpose PVC/CPVC/ABS cleaner primer
- An NSF® approved all purpose PVC/CPVC/ABS cement

#### **WARNING!**



When using electrical products, basic precautions should always be followed, including the following:

- **DANGER: RISK OF ELECTRIC SHOCK, WHICH CAN RESULT IN SERIOUS INJURY OR DEATH.** Before attempting installation of service, ensure that all power to the circuit supplying power to the system is disconnected/turned off at the circuit breaker. It is recommended, but not mandatory that the IntelliChlor Power Center be connected to a circuit protected by a ground fault circuit-interrupter (GFCI).
- Grounding (earth bonding) is required. The unit should be installed by a qualified service person and grounded.
- Install to allow access to cell buttons and power center.
- **Read Safety Precautions and Important Instructions (page ii and iii). Before attempting any electrical wiring, be sure to read and follow Safety Instructions. Wiring should only be performed by a qualified professional.**
- Install the IntelliChlor unit a minimum of three (3) feet away from the heater outlet.
- Pipe couplings: Schedule 80, maximum pressure 150 psi at 70° F (21° C).
- **Note:** Operate unit with minimum flow of 25 gpm. For high flow applications, use a bypass loop (see page 4).

## IntelliChlor “Dummy” Cell

After new pool construction has been completed, in order to prevent debris from entering the IntelliChlor Electronic Chlorine Generator, it is recommended that the IntelliChlor Electronic Chlorine Generator “dummy” cell (P/N 520588) be installed before installing the IntelliChlor Electronic Chlorine Generator. After the pool system has flushed the debris from the pipes, remove the “dummy cell” and install the IntelliChlor Electronic Chlorine Generator.

## Installing the IntelliChlor Cell Assembly

Install the IntelliChlor cell assembly no closer than three (3) feet away from the heater outlet, if used. For more information see plumbing diagrams on page 4 and 5.

*Note: After new pool construction has been completed, in order to prevent debris from entering the IntelliChlor cell assembly, it is recommended that the IntelliChlor pass-through cell (P/N 520588) be installed before installing the IntelliChlor cell. After the pool system has flushed the debris from the pipes, remove the pass-through cell and install the IntelliChlor cell.*

*Note: Pipe couplings: Schedule 80, maximum pressure 75 psi at 70° F (21° C)*



IntelliChlor Electronic Chlorine Generator (model IC15)

To install the cell:

1. Using PVC glue, mount the PVC couplings to the plumbing pipe. Allow the glue to dry.
2. Mount the cell to allow access to the control panel. Install the cell onto the couplings. Ensure the O-rings are seated properly.
3. Switch on the pump and visually inspect for leaks around the couplings.

### Connecting the Power Supply Cable to the IC15 Cell

**⚠ WARNING** - Switch OFF main system power to the Power Center before making any connections.

After the IC15 cell installation is completed, connect the cell power cable to the Power Supply:

- Align the four (4) pins of the cell power cord connector with the socket on the side of the Power Supply and insert the connector. Turn the round socket nut until it locks the connector in place.

Power Supply connector



IC15 Power Supply

Blank Page

# Section 6

## Troubleshooting

Use the following troubleshooting information to resolve possible problems with the IntelliChlor Electronic Chlorine Generator.

*Note: Switch power off to unit before to attempting service or repair. Always remove AC power to Power Supply when plugging or unplugging the IntelliChlor cell into the Power Supply.*

**Table 1: Troubleshooting**

Problem	Possible Cause	Corrective Action
Low or no chlorine.	Low stabilizer (cyanuric acid) level in pool water (outdoor pools only).	Add cyanuric acid in outdoor pools only to maintain 50 - 80 PPM per pool professional's recommendations. See Stabilizer Chart, Table 3, page 14.
	Insufficient operating hours of the IECG.	Increase the IECG operating time per day. See page 17.
	SANITIZER OUTPUT percentage set too low or off at 0%.	Increase SANITIZER OUTPUT by pressing the MORE button. See page 8.
	Recent increases in weather temperature without increasing the IECG Sanitizer Output.	Increase SANITIZER OUTPUT by pressing the MORE button. See page 8.
	Temporary loss of chlorine due to heavy organic load, rain, leaves, fertilizer or heavy bather load, recent party, or pets using pool.	Set "Boost" mode and allow to run for 24 hours. Recheck, If still too low, super-chlorinate by using an outside source. (Take pool water sample to pool professional).
	Low (less than 2600 ppm) salt level in pool water.	Observe Salt Display lights. See "Salt Level Status LEDs," page 7.
	High nitrate and phosphate level.	Contact Pool Professional.
	Metals present in pool water.	Contact Pool Professional.
	New pool water, or not shocked properly upon startup.	Super Chlorinate Pool. See "Start-up Procedure (Super Chlorination)", page 18.
	Clogged or dirty cell.	Remove cell for inspection. Clean if necessary. (see page 22).

**Table 1: Troubleshooting (Continued)**

<b>Problem</b>	<b>Possible Cause</b>	<b>Corrective Action</b>
Red ADD salt light is on	Pool water needs salt. No chlorine is being produced.	Add salt as described on page 13 and 14.
Red ADD SALT light is flashing	Not enough salt in pool. Heavy Rainfall. Leak in pool.	Add salt to pool to achieve 3200 ppm to 4500 ppm. See page 13 and 14.
Green GOOD salt light is flashing	Too much salt in pool. May cause excessive corrosion to pool equipment and surfaces in and around pool.	Dilute pool water by draining some water one foot at a time, then refilling with fresh water.
PWR light is red	Call for service.	IECG requires attention.
Cell light does not come on	Chlorine Production set to 00%.  Insufficient water flow. Cell is plugged with debris.  Water is below 52°F (11° C).  Pump has lost prime. Salt level below 2500 ppm.	Adjust CHLORINE PRODUCTION to desired percentage.  Remove obstruction and/or clean cell. Refer to "Cleaning the IECG Blades" for acid wash/cleaning. See "page 22."  Press the MORE button to enter status mode for 2-1/2 seconds. During this time the LED will turn red if the system is in "freeze" mode (water below 52° F not producing chlorine). The pool water temperature must be above 52° F (11° C) to produce chlorine.  Prime pump if necessary. Refer to pump owners manual for priming instructions. Add another CORRECTIVE ACTION
Cell light is flashing GREEN	IECG blades have calcium build-up and require cleaning.	Refer to "Cleaning the IECG Blades" for acid wash/cleaning. See "page 22."
Flow light is red	Pump fails to provide sufficient water flow.	Check for correct operation of the pump, i.e., loss of pump prime or clogged strainer baskets.
	Closed valves.	Check and correct all valve alignments.
	Dirty filter.	Follow filter cleaning procedures.
	Obstruction in the IECG.	Remove IECG for inspection. Follow cleaning procedures. See "IECG Blade Cleaning," on page 22.
IECG does not have green power light.	Fuse in Power Center is open.	Replace AC fuse, located at bottom of Power Center.
No AC power to Power Center.	Transformer leads not wired correctly in Power Center.	Verify time clock is providing AC electrical current to Power Center when active.  Verify transformer leads wired to AC source by referring to wiring diagram decal on inside of Power Center cover.

## System Specifications and Wiring

**Circuit Protection:** Two-pole 20 AMP device at the electrical panel.

### IntelliChlor Model IC15

Input: 85-130 VAC, 50/60 Hz, 65 watts

Output: 24 VAC (4 AMPS) to internal blades of cell.

Chlorine: 0.60 lb / 24 hours (272 gm / 24 hours)

Water flow: 20 gallons per minute minimum. 105 gallons per minute maximum. Maximum pressure: 75 psi

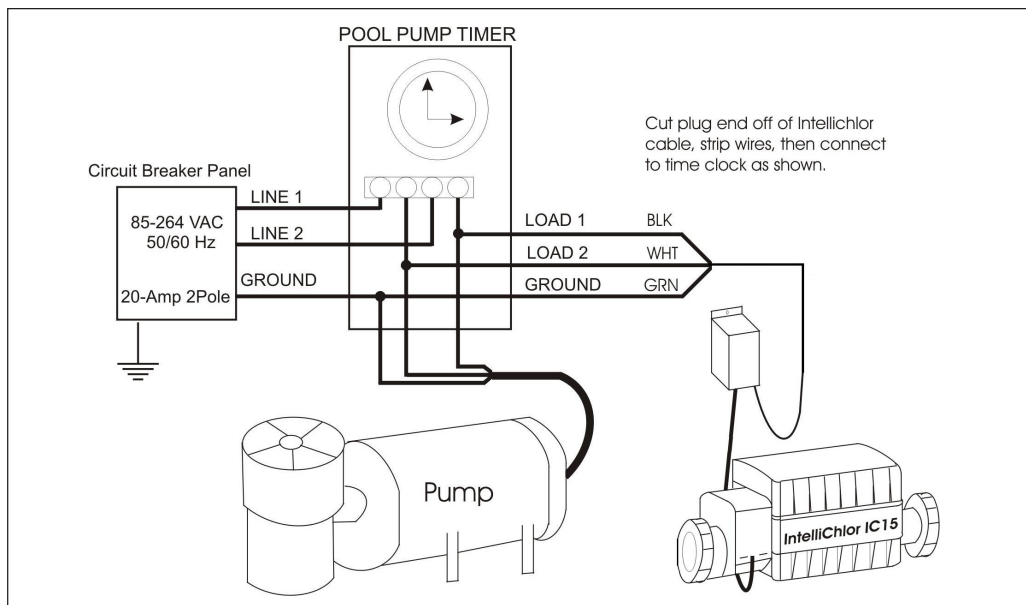
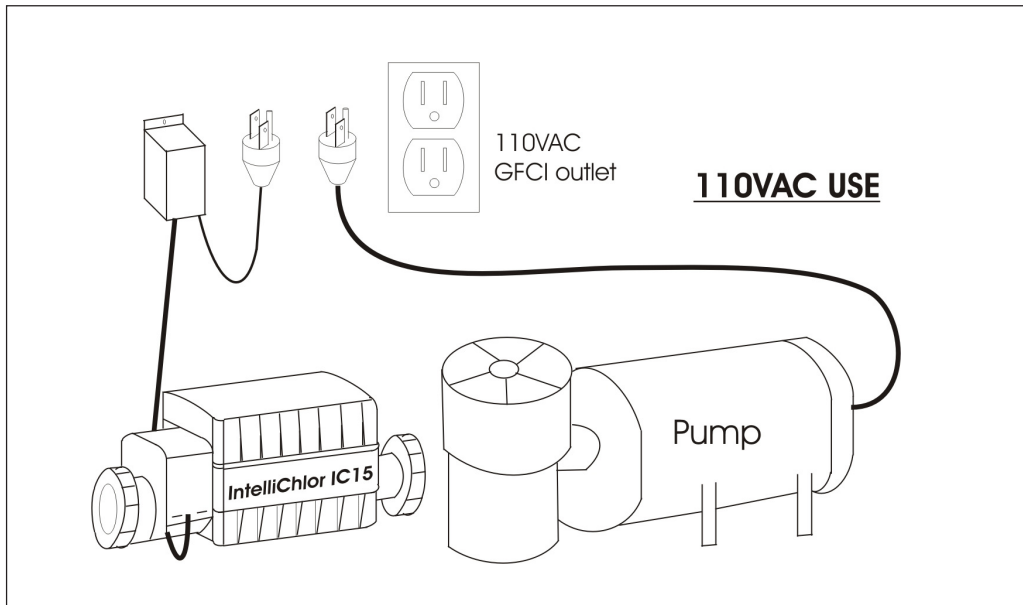

## 110 VAC Basic System Wiring

## LIMITED WARRANTY

Pentair Water Pool and Spa, Inc. ("Pentair Water") warrants the IntelliChlor® Electronic Chlorine Generator (IECG) as follows:

**IECG 15 Cell Limited Warranty:** Pentair Water warrants the IECG to be free from defects in material and/or workmanship for a period of three (3) years or 8,000 hours (parts only) from the original date of installation.

**IECG 15 Power Supply Limited Warranty:** Pentair Water warrants the IECG Power Center to be free from defects in material and/or workmanship for a period of one (1) year (parts only) from the original date of installation.

*Exceptions that shall result in Pentair's denial of a warranty claim:*

1. Damage caused by careless handling, improper repackaging, or shipping.
  2. Damage due to misapplication, misuse, abuse or failure to operate equipment as specified in the IECG Installation and User's Guide.
  3. Damage caused by failure to install products as specified in the IECG Installation and User's Guide.
  4. Damage due to unauthorized product modifications or alterations, or failure to use Pentair Water original replacement parts.
  5. Damage caused by negligence, or failure to properly maintain products as specified in the IECG Installation and User's Guide.
  6. Damage caused by failure to maintain water chemistry in conformity with the standards set forth in the IECG Installation and User's Guide.
  7. Damage caused by water scaling, freezing or any conditions causing inadequate water circulation.
  8. Accidental damage, fire, acts of God, or other circumstances outside the control of Pentair Water.
- This warranty extends to the original retail owner (Customer) only, beginning on the date of installation and is not enforceable by any other party. Proof of purchase and/or date of installation will be required for all warranty claims. Customer agrees to pay all shipping charges to Pentair Water.
  - Warranties by others: Some products incorporate components manufactured by other manufacturers. Some of these provide warranties in addition to the warranty provided herein. In all such cases a copy of that warranty will be provided with the product. To the extent protection provided under any such third party warranty exceeds the Limited Warranty provided herein, the Customer must look only to that other manufacturer for the additional warranty protection.

**Warranty Obligations of Pentair Water:** Should a defect in workmanship and/or material in any item covered by this warranty become evident during the term of the warranty, then upon the Customer following the procedures set forth below, Pentair Water will, at its option, repair or replace such item or part at its own cost and expense. Pentair Water's maximum obligation under this warranty is limited to the repair and replacement of the IECG. Pentair Water disclaims all other expressed or implied warranty obligations.

Pentair Water is not, however, responsible under this warranty for any cost of shipping or transportation of the equipment or parts thereof to or from Pentair Water's Technical Service Department. Also, Pentair Water is not liable for any loss of time, inconvenience, incidental expenses such as telephone calls, labor or material charges incurred in connection with the removal or replacement of the equipment, or any other incidental or consequential damages, including but not limited to damage to pool equipment or any surface in or around the pool in which the IECG is installed.

PLEASE NOTE: Some states do not allow the exclusion or limitation of incidental, or consequential damages, so the above limitation or exclusion may not apply to you.

**No Other Warranties:** TO THE MAXIMUM EXTENT PERMITTED BY APPLICABLE LAW, PENTAIR WATER DISCLAIMS ALL OTHER WARRANTIES, WHETHER EXPRESS OR IMPLIED, INCLUDING, BUT NOT LIMITED TO THE IMPLIED WARRANTIES OF MERCHANTABILITY AND FITNESS FOR A PARTICULAR PURPOSE.

Continued on next page.

### LIMITED WARRANTY (Continued)

**Procedure for Obtaining Performance:** In order to obtain the benefits of this warranty, the Customer who made the original retail purchase must contact the Pentair Water Technical Service Department upon discovery of the defect, but in no event later than the expiration date of the warranty period provided in this warranty. Upon receipt of this communication, Pentair Water will promptly notify the Customer of the address to which the defective item may be shipped. The Customer shall then ship the item, freight prepaid, to the address indicated, together with a "RETURN GOODS AUTHORIZATION" form obtained from Pentair Water's Technical Service and a brief description of the problems encountered. Unauthorized returns will not be accepted. Freight must be prepaid by customer.

**Warranties or Representations by Others:** No dealer or other third party entity has any authority to make any warranties or representations concerning Pentair Water or its products. Accordingly, Pentair Water is not responsible for any such warranties or representations.

**Other Rights:** This warranty gives you specific legal rights and you may also have other rights, which vary from state to state. This warranty supersedes all previous publications.

PENTAIR WATER POOL AND SPA, INC.

1620 Hawkins Ave. Sanford, NC 27330 - 10951 W. Los Angeles Ave. Moorpark, CA 93021 - Phone 800-831-7133 - Fax 800-284-4151



**WARNING:** Salt is an inherently corrosive material. While the levels of salt required for proper operation of the IntelliChlor Electronic Chlorine Generator (model IC15) are relatively low when compared to sea water and other salt solutions, placing any amount of salt in your pool increases the likelihood of corrosion or other deterioration of pool equipment and any surfaces used in and around your pool. Metal parts and certain natural and man-made surfaces are particularly susceptible to corrosion and deterioration when used in and around salt water pools. Pentair Water Pool and Spa does not represent or otherwise guarantee that the proper use of the IntelliChlor Electronic Chlorine Generator will prevent corrosion or other deterioration of pool equipment and any surfaces used in and around your pool. Consult your experienced pool professional, who should be able to advise you on the proper material selection, installation techniques for those materials, and the proper use, care and maintenance of those materials for your specific pool type and location in order to minimize the corrosion and deterioration that is inherent in and around salt water pools.



P/N 520898 - Rev B