

**SWIMMING POOL PUMP AND FILTER SYSTEM**

**READ AND FOLLOW ALL SAFETY INSTRUCTIONS**

# For Homeowner Only

# Important

# Information

# Enclosed

# SWIMMING POOL PUMP AND FILTER SYSTEM

## INSTALLATION, OPERATIONAL & SERVICE MANUAL

**For Homeowner Only**

Important  
Information  
Enclosed

***FILTER IS DESIGNED AND INTENDED FOR USE TO FILTER WATER IN SWIMMING POOLS AND SPAS.***

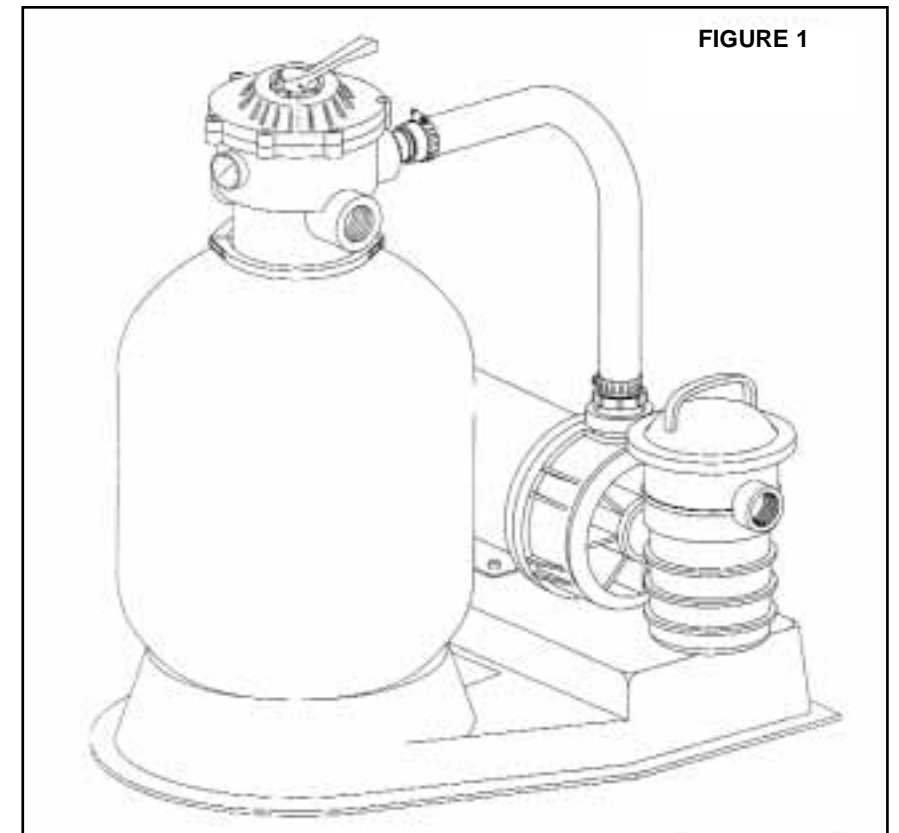

**⚠ WARNING**

**THIS MANUAL CONTAINS CRITICAL SAFETY INFORMATION WHICH MUST BE FURNISHED TO THE END USER. FAILURE TO READ AND FOLLOW INSTRUCTIONS COULD RESULT IN SERIOUS PERSONAL INJURY AND/OR MAJOR PROPERTY DAMAGE.**

### TABLE OF CONTENTS

A. How Your System Works .....	2	H. Replacement of Valve Top and Diverter Assembly .....	7
B. Installation .....	3	I. Winterizing the Components .....	7
C. Initial Start-Up .....	5	J. Trouble Shooting .....	
D. Component Care .....	6	K. Replacement Parts List-6 Way Valve .....	8
E. Cleaning Frequency .....	6	L. Replacement Parts List-Sand Filter .....	9
F. Filter Backwash Procedure .....	6	M. Replacement Parts List-Centrifugal Pump .....	10
G. Chemical Cleaning .....	6	N. Replacement Parts List-System Plumbing .....	11



*Because reliability matters most*

# INSTALLATION, OPERATIONAL & SERVICE MANUAL

## SWIMMING POOL PUMP AND FILTER SYSTEM

This system operates under pressure and if assembled improperly or operated with air in the water circulation system it can separate and result in an accident causing serious bodily injury. A warning label has been affixed to the filter and should not be removed. Keep safety labels in good condition and replace if missing or illegible. (For free labels call 1-919-774-4151).

Filters should never be tested or subjected to air or gas under pressure. All gases are compressible and under pressure create a danger. Severe bodily injury or property damage could occur if the filter is subjected to air or gas pressure.

### A. How Your System Works

The system consists primarily of a centrifugal pump, a high rate sand filter with control valve, a connecting hose and a mounting base.

Your centrifugal pump is driven by an electric motor. The motor is directly attached to the pump impeller. As the electric motor turns it causes the impeller to turn and this causes the water to flow. The water flows into the hair and lint pot inlet and through the basket assembly to prestrain large particles. The flow then enters the center of the pump housing. The flow goes through the impeller into the stationary diffuser, out the pump discharge port, through the connecting hose and into the filter control valve.

Dirt is collected in the filter as the water flows through the control valve at the top of the filter and is directed downward onto the top surface of the filter sand bed. The dirt is collected in the sand bed and the clean water flows through the lower piping at the bottom of the filter up through the center pipe into the control valve at the top of the filter. Clean water then returns through the piping system to the pool.

The pressure will rise and the flow to the pool will be lowered as the dirt is collected in the filter. Eventually, the filter will become so plugged with dirt that it will be necessary to perform the backwash procedure. It is important to know when to backwash the filter. Backwashing is discussed further under the subsequent sections of this booklet.

Your six position valve is designed to provide all the necessary positions required to operate, maintain,

trouble shoot and service your filter. It is provided with six operating positions and one Winterize position.

**WARNING**  
Air entering the filter and a valve clamp not closed properly can cause the valve to blow off and could cause severe bodily injury and/or property damage.

The valve is equipped with an external air bleeder device. Always open this air bleeder and stand clear of filter and valve before starting the system pump and leave open until a steady stream of water is expelled.

**CAUTION:** To prevent equipment damage and possible injury, always turn pump off before changing valve position.

The valve has a closed position. The pump should never be on when the valve is in the closed position. If the pump is operated with the valve closed, the air relief system becomes inoperative and an explosive situation could exist. Additionally, running the system with no flow will seriously damage the equipment.

### VALVE POSITIONS AND WATER FLOW DIRECTIONS

- FILTER -** From pump, through valve downward thru filter sand bed, up through center pipe to valve RETURN port for normal filter action and vacuuming pool thru filter.
- BACKWASH-** From pump through valve, down through center pipe, upward thru sand bed, and to valve WASTE port for cleaning filter by reversing flow.
- RINSE -** From pump through valve downward thru filter sand bed, up through center pipe to valve WASTE port for start-up cleaning and resetting filter bed after backwashing.
- WASTE-** From pump through valve bypassing filter going to WASTE port for vacuuming directly to waste, lowering pool level, or draining pool.
- CLOSED-** NO FLOW - DO NOT USE THIS SETTING WITH PUMP OPERATING.
- RECIRCULATE-** From pump, through valve, bypassing filter and going to return port for circulating water without going thru filter.

Please note that a filter removes suspended matter and does not sanitize the pool. The pool water must be sanitized and the water must be balanced for sparkling clear water. Pool chemistry is a specialized area and you should consult your local pool service

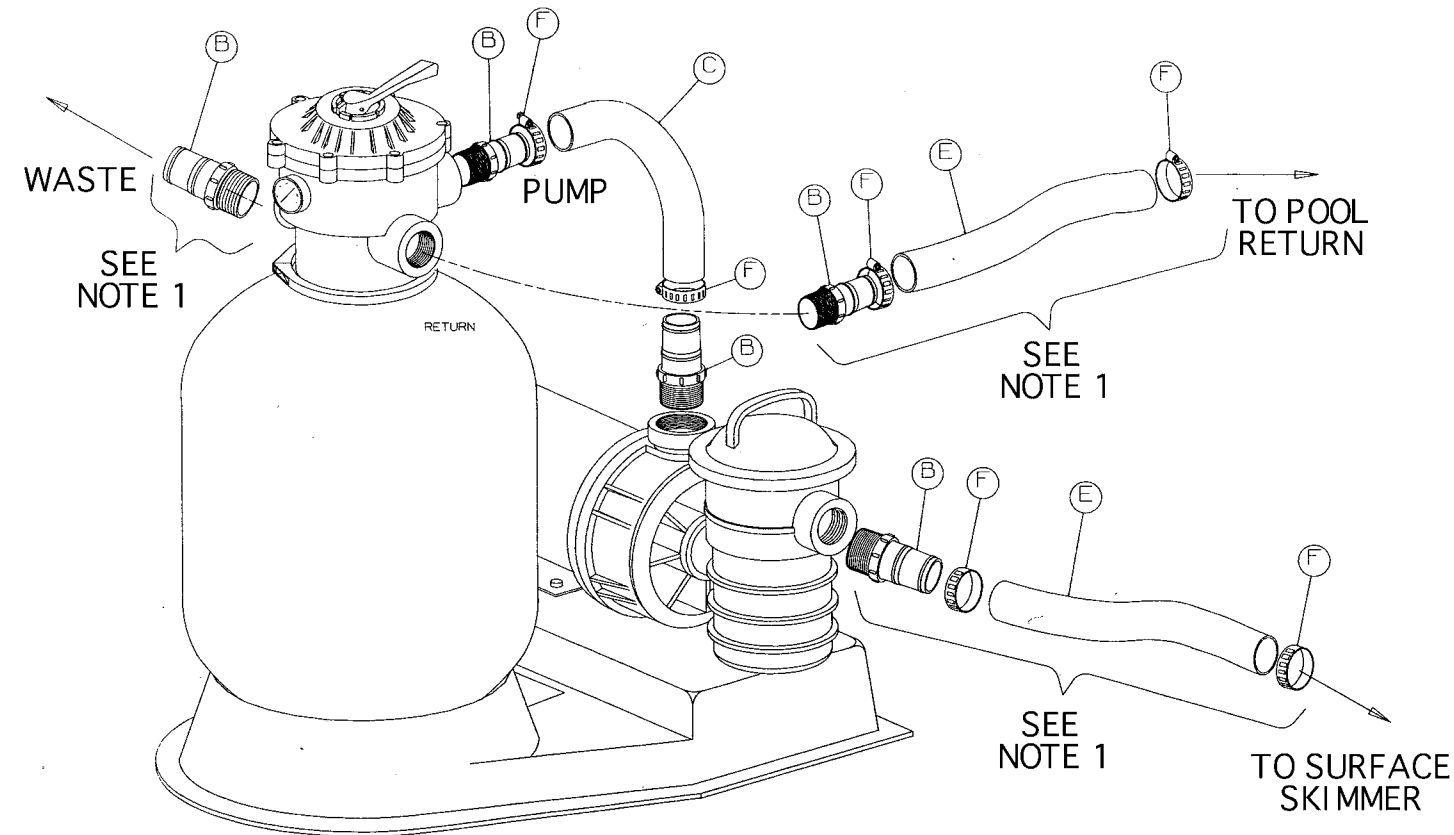

**NOTE 1:** These parts are furnished only when system is purchased with a hose kit.

### N. Replacement Parts List - System Plumbing

Item	Part No.	Description	Qty.
B	71-1006	Adaptor Double Step	6
C	See Note	PVC Hose	1*
E	15-5153	Flex Hose 1 1/2" x 6'	2*
F	71-1004	Hose Clamp 1 1/2"	6

**NOTE:**  
1. Replacement hose with hose Adaptor (item C) may be ordered by giving filter system model number.

**M. Replacement Parts List - Pump**

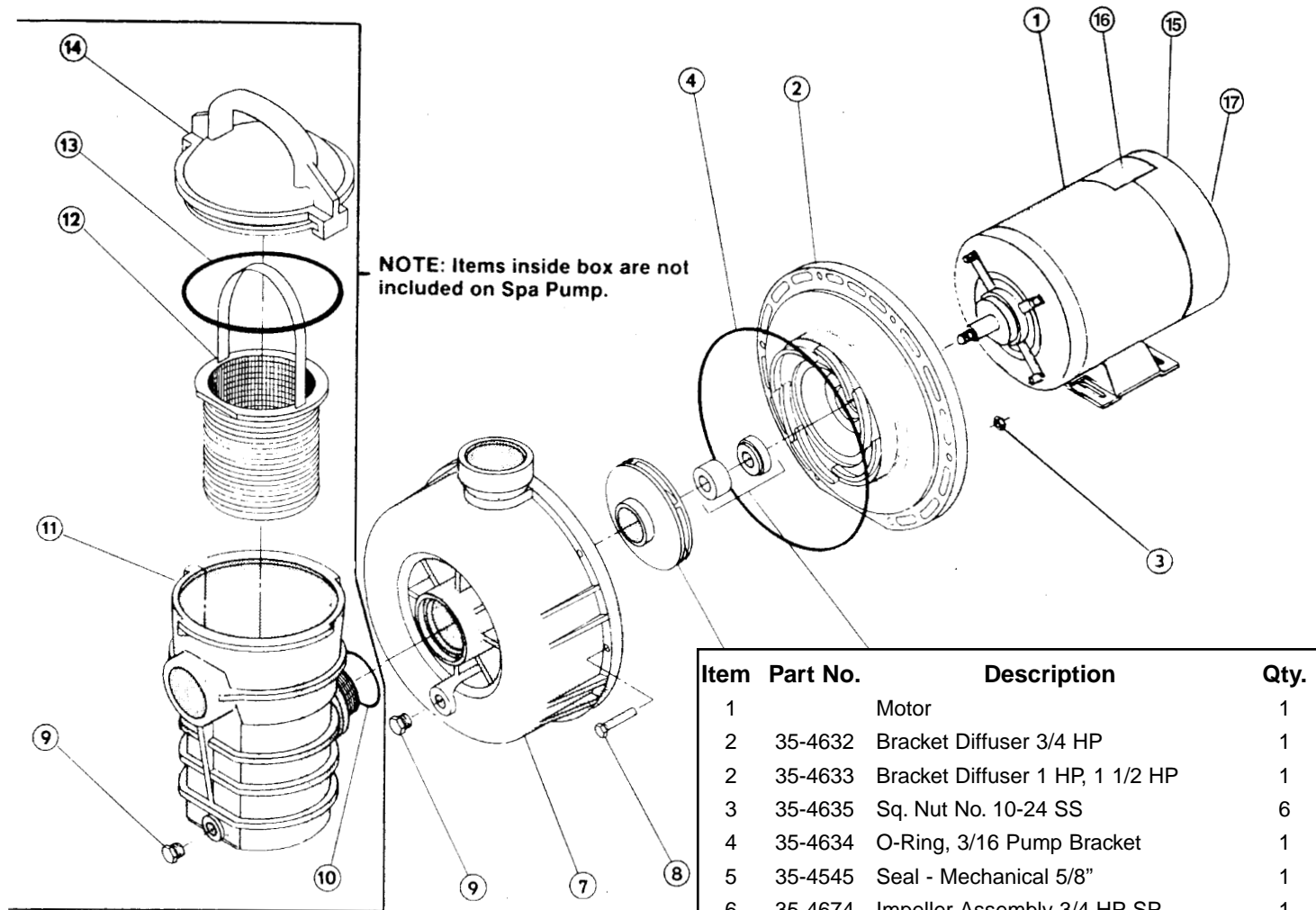

Item	Part No.	Description	Qty.
1		Motor	1
2	35-4632	Bracket Diffuser 3/4 HP	1
2	35-4633	Bracket Diffuser 1 HP, 1 1/2 HP	1
3	35-4635	Sq. Nut No. 10-24 SS	6
4	35-4634	O-Ring, 3/16 Pump Bracket	1
5	35-4545	Seal - Mechanical 5/8"	1
6	35-4674	Impeller Assembly 3/4 HP SP	1
6	35-4663	Impeller Assembly 1 HP, 1 1/2 HP	1
6	35-5122	Impeller Assembly 1 1/2 HP	1
7	35-4630	Housing - Body	1
8	35-4636	Screw-Slotted Hex No. 10-24-1 1/2"	6
9	15-4481	Plug 1/4"	2
10	27-3062	O-Ring	1
11	35-4530	Pot	1
12	35-4548	Basket Assembly	1
13	35-4533	O-Ring Lid	1
14	35-4531	Lid	1
15	35-4563	Label - Warning	3
16	35-3401	Decal - Ground Information	1
17	35-3430	Label - Conductor	1
	35-2244	Caution Tag (See notes)	1

**NOTE:**

1. For replacement cord or motor consult factory customer service.

specialist for specific details. In general proper pool sanitation requires a free chlorine level of 1 to 2 PPM and a PH range of 7.2 to 7.6.

Your filtration system should be designed to meet your local health codes. As a minimum, you must be sure that your system will turnover the total volume of water in your pool at least twice in a twenty-four hour period.

**⚠ WARNING**

Failure to operate your filter system or inadequate filtration can cause poor water clarity obstructing visibility in your pool and can allow diving into or on top of obscured objects, which can cause serious personal injury or drowning.

**B. Installation**

1. Read and understand all instructions before attempting to install, operate or maintain your pump and filter system. Due to the different models some instructions may not apply to your specific system or certain instructions may be duplicated in other component manuals.

2. Provide space and lighting for routine maintenance access. Locate the system close to the pool. See Diagram C for typical system installation.

Do not mount electrical controls over the filter. One needs to be able to stand clear of the filter when starting the pump. Systems that are unassembled should be assembled at this point. See special instructions A thru E below.

A. Remove all individual components from carton and inspect for any visible damage. If carton or parts are damaged contact seller or freight company.

B. Place the system support base on the ground close to the final location of the unit. See Diagram A.

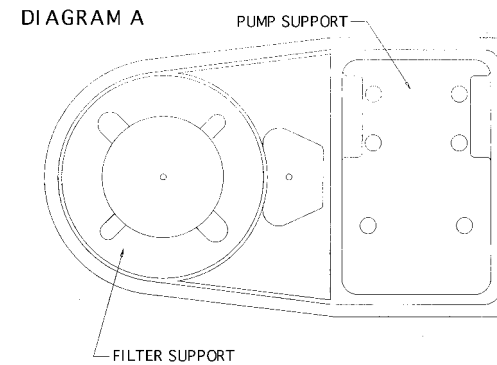

C. Examine the bottom of the filter and confirm the orientation of the four small mounting protrusions on the tank.

D. Align the protrusions on the tank with the

dimples in the filter support portion of the base and place the filter on the base.

E. The pump may now be attached to the pump support side of the base using two bolts. The pumps should be positioned as indicated in Diagram B.

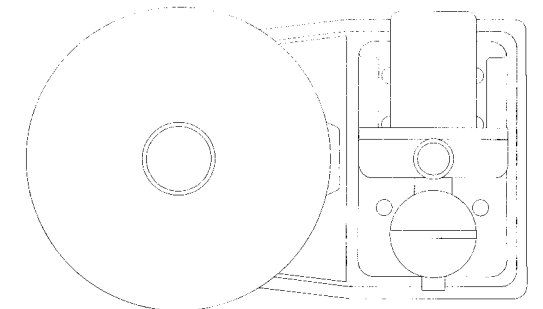

DIAGRAM B

3. At this point you need to move the system into its final position. The system must be placed on level solid earth. The entire system filled with sand and water can weigh several hundred pounds.

4. Be certain to install the precise amount of filter sand listed on your filter nameplate. You must use only No. 20 standard silica sand having a uniformity coefficient of 1.75 or less. No. 20 silica sand has a particle size of .018-.022 inches (.45 to .55 mm). Before pouring the sand into the filter, look inside and check the lower underdrain for broken or loose laterals (or fingers), which may have been accidentally damaged by rough handling during shipment. Replace any broken parts if necessary.

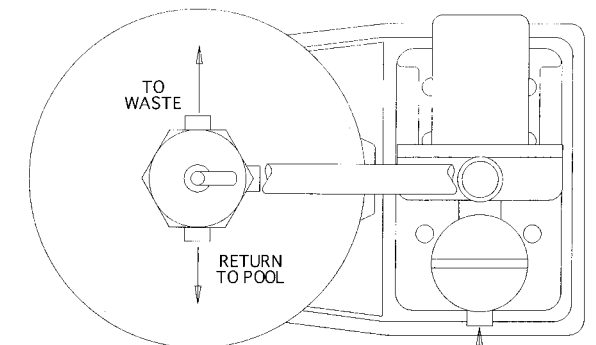

DIAGRAM C

5. Install the sand guide in the top of the filter and fill the tank about half full with water. Pour the sand into the top of the filter at a slow rate so that the weight of the sand does not damage the laterals. After filling to the proper level, remove and discard the sand guide. Wash away all sand around the opening at the top of the tank.

6. Be sure top of filter is free of any sand or debris

and valve o-ring is in place on valve body. Install valve so that the port locations are in the desired final position. See Diagram C.

7. Insure that the valve is firmly pushed into the top of the tank and that the flange of the tank and the flange of the valve are contacting each other. See Diagram D.

DIAGRAM D

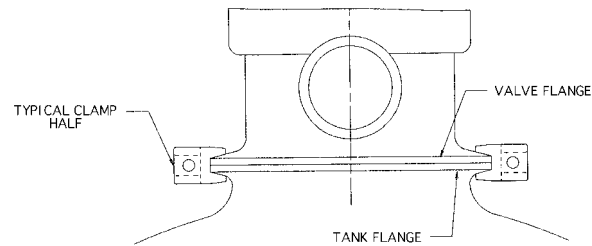

8. The plastic clamp can now be installed. Place the clamp half over the valve flange and the tank flange as shown in diagram D. Insert the valve screws and nuts into the clamp half making sure that the nuts are located in the special hexagonal retainer slots on the clamps. See Diagram E.

9. Tighten clamp screws firmly and visually check the valve tank and clamp assembly to insure that the joint is correctly assembled.

<b>⚠ WARNING</b>
Improper tank valve assembly could cause the valve to blow off and cause severe injury and/or property damage.

10. Valve ports are labeled with the location of where they should be connected i.e. pump port must go to pump discharge, waste port must go to the waste line and return port must go to the pool return.

11. The filter unit has a maximum operating pressure listed on the filter name plate. **DO NOT OPERATE** this unit above the maximum operating pressure of the valve or the filter. Never connect the filter and valve unit to a pump which can generate a pressure that exceeds the operating pressure of the filter or valve.

12. Use sealant on all tapered male connections of pipe and fittings. Use only sealant compounds suited for plastic pipe. Support pipe to prevent strains on filter, pump or valve. **DO NOT USE PETROLEUM BASED PRODUCTS.** NOTICE: All valve Internal threads are tapered except the air bleeder connection. Do not over tighten tapered thread connection.

13. Install pressure gauge in 1/4" NPT port directly across from the pump port of the valve.

14. Never store pool chemicals within 10 feet of your pool filter, pump or valve. Pool chemicals should always be stored in a cool, dry, well ventilated area.

<b>⚠ WARNING</b>
Chemical fumes and/or spills can cause severe corrosive attack to the filter and pump structural components. Structurally weakened components can cause filter, pump or valve attachments to blow off and could cause severe bodily injury or property damage.

<b>⚠ WARNING</b>
The system's centrifugal pump operates with electrical voltage, and can generate both vacuum and pressure in the water system. When properly wired and plumbed, this pump will operate in a safe manner.

<b>⚠ WARNING</b>
Hazardous voltage - can cause severe or fatal injury. Always install a suitable GFCI at the power source of this unit as an added safety precaution. Article 680-31 of the NEC requires that a GFCI be used if this pump is used with storable pools.

15. Avoid over tightening the pipe threads when connecting fittings to the pump or valve. Proper procedure is to apply a pipe sealant to the thread and then install hand tight plus 1 turn. **DO NOT OVER TIGHTEN.**

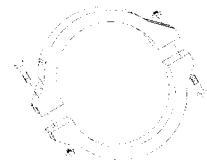

16. The pump suction line should not be smaller than the pipe size on the inlet of the pump.

17. Electrical connection of the pump should be performed by a licensed electrician in accordance with the National Electrical Code or your local electrical code.

RECOMMENDED CIRCUIT BREAKER AND WIRING DATA					
Motor HP	Branch Circuit	Volts/Hz /Phase	Dist. in Ft. of Branch Circuit		
			0-50 Ft.	50-100 Ft.	
3/4	15 AMP	115/60/1	#14	#14	Min. Service
1	15 AMP	115/60/1	#12	#12	Wire
1-1/2	20 AMP	115/60/1	#12	#10	Size
1-1/2	15 AMP	230/60/1	#14	#14	To Motor

**L. Replacement Parts List - Sand Filter**

Item	Part No.	Description	Qty.
2	71-1006	Adaptor - 1 1/2" Hose	2
3	71-1004	Clamp - Hose	2
4	15-4893	Hose - 18 3/4" SD35	1
4	15-4894	Hose - 24 1/2" SD40	1
4	15-4895	Hose - 29 1/4" SD50	1
5	15-2165	Clamp Assembly	1
6	15-2168	Screw - #M6 x 1	2
7	15-2166	Clamp Half	2
8	15-2167	Nut - #M6 x 1	2
9	35-1376	Pump - DynII-NI - 3/4	1
9	35-1377	Pump - DynII-NI - 1	1
9	35-1378	Pump - DynII-NI - 1 1/2	1
10	35-4265	Screw - 5/16 x 18 Hex Hd	2
11	15-5109	Nut-T4	2
12	15-2901	Base - Elevated System	1
13	15-4699	Drain Plug	1
14	19-2115	O-Ring-Drain Plug	1
15	15-4710	Drain - Sand 1"	1
16	15-4713	Gasket - Sand Drain	1
17	15-5007	Lateral - SD35	8
17	15-2290	Lateral - SD40/50	8
18	15-5504	Piping Assembly (Dim. D.=14 3/8")	1
18	15-5062	Piping Assembly (Dim. D.=18 1/4")	1
18	15-5532	Piping Assembly (Dim. D.=23 1/4")	1
19	71-0015	Tank - SD35	1
19	71-0016	Tank - SD40	1
19	71-0017	Tank - SD50	1

**NOTE:**  
1. Order filter tank by giving tank color and filter model number. The model number is identified on the filter nameplate.

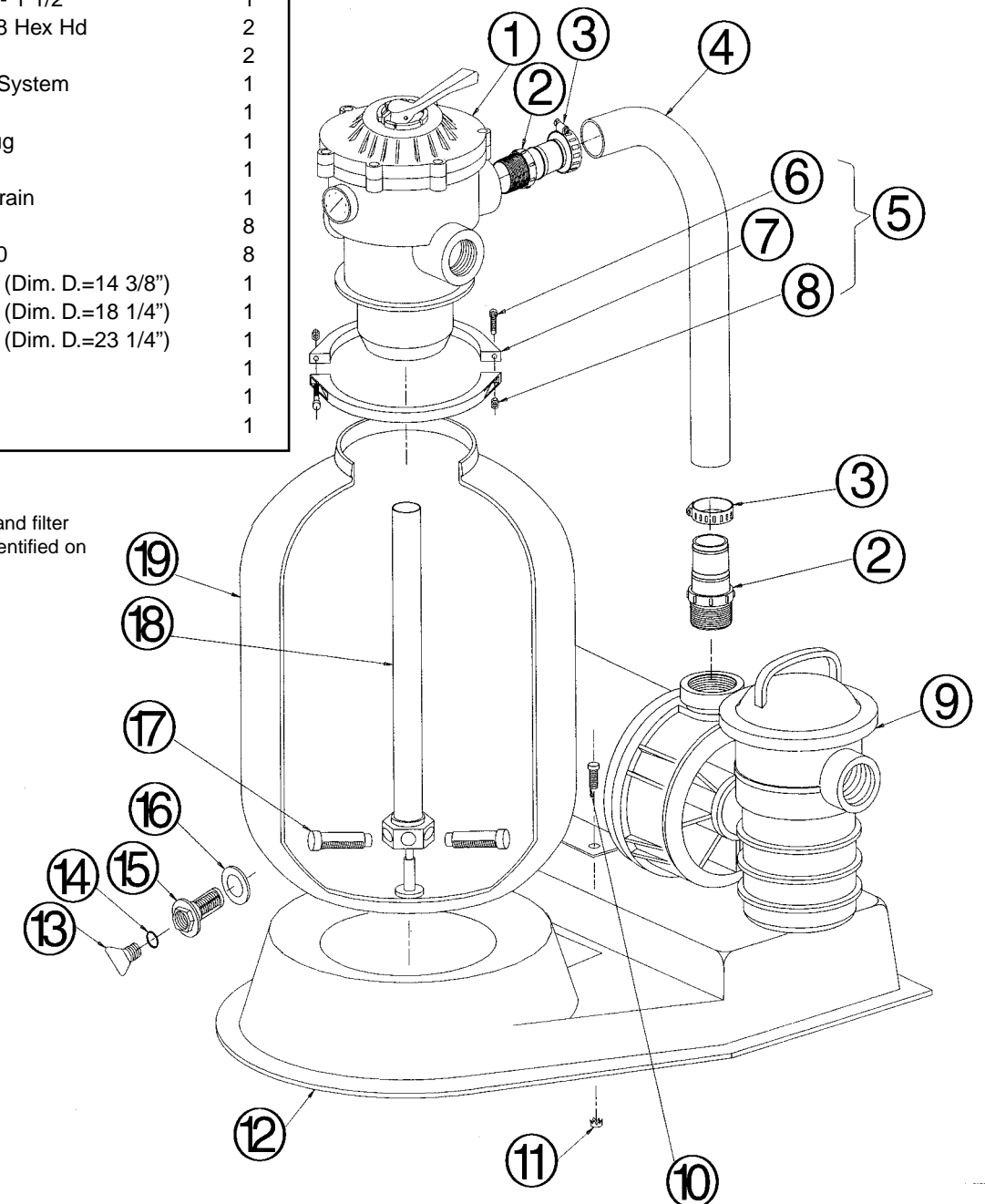

**K. Replacement Parts List - 6 Way Valve**

Item	Part No.	Description	Qty.
1	27-2520	Handle	1
2	27-2505	Washer-Plastic	2
3	27-2405	Screw-Handle	1
4	27-2527	Valve Top - Black	1
5	27-2511	O-Ring-Diverter Shaft	1
6	35-4053	O-Ring	1
7	27-2535	Spring - 100 Lb. - 1 3/8 O.D. SS	1
8	27-2512	Diverter W/Gasket	1
9	35-4636	Screw #10-24 Hex Pan HD	6
10	15-2946	Washer 9/16 SS	6
11	15-2945	Nut - #10-24 Serrated Flange SS	6
12	27-2530	Valve Body W/Differ - Clamp Style	1
13	27-3512	Air Bleeder W/O-Ring	1
14	27-2541	O-Ring - 3/16" x 4 5/8" I.D.	1
15	15-2165	Clamp Assembly (See Note 2)	1
16	15-5050	Pressure Gauge	1
17	15-2166	Clamp Half	2
18	15-2168	Screw #M6X1 Pan HD Phillips SS	2
19	15-2167	Nut #M6SS	2

**NOTE:**

1. Valve Top Assembly P/N 27-2531 consists of items 1 thru 8 and valve instructions 27-2517.
2. Clamp Assembly P/N 15-2165 consists of items 17 thru 19.

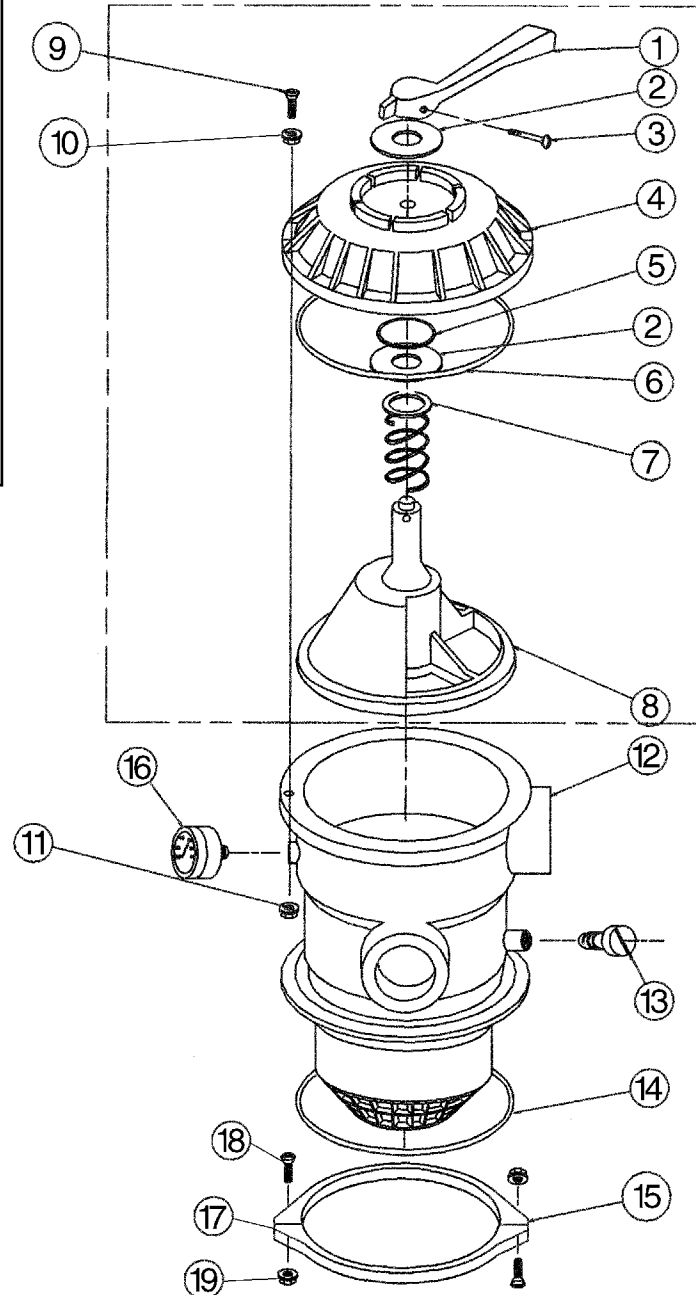

**WARNING**

Blockage of suction fittings can cause severe or fatal injury due to drowning. Small children using pool/spa equipment must always have close adult supervision. To reduce the risk of injury, do not permit children to use this product unless they are closely supervised at all times.

**WARNING**

Never work on pump while it is running or power is still connected; Hazardous voltage can cause severe or fatal injury. A suitable ground fault interrupter should always be installed at the power supply source of this unit. Ground motor before connecting to electrical power supply. Failure to ground motor can cause severe or fatal electrical shock hazard. Do not ground to a gas supply line.

18. Use lug on top of motor frame to bond together motor and all metallic parts of pool, spa, or hot tub structure and all electrical equipment, metal conduit, and metal piping with a solid copper conductor not less than No. 8 A.W.G.

19. The pump motor must be wired for the proper voltage in accordance with the wiring diagram supplied with the motor. (Wiring the motor with the incorrect supply voltage will cause damage to the motor and void the warranty.)

20. The wiring to the motor should be kept as short as possible and large enough NOT to cause an excessive voltage drop which could damage your pump. Use the chart on Page 4 as a guide to ensuring adequate voltage is supplied to the pump.

21. The product may be furnished with a 6' - 3 prong Test Cord. The cord is provided for your convenience to allow you to check the pump operation before installing the system on the pool. The test cord should NOT be used for permanent connection.

When checking the pump operation do not run the unit longer than 30 seconds. Damage to the pump on mechanical seal could result if ran longer than 30 seconds.

**WARNING FOR CORD AND PLUG-CONNECTED UNITS**

**RISK OF ELECTRICAL SHOCK** - Connect only to a grounding type receptacle protected by a ground Fault Circuit Interrupter (GFCI). Contact a qualified electrician if you cannot verify that the receptacle is protected by GFCI.

Do Not Bury Cord. Locate cord to minimize abuse from lawn mowers, hedge trimmers, and other equipment.

To reduce the risk of electric shock, replace damage cord immediately.

To reduce the risk of electric shock, Do Not Use an extension cord to connect unit to electric supply; provide a properly located outlet.

**C. Initial Start-up**

1. Clean a new pool before filling it with water. Excessive dirt and large particles can cause damage to your pump and filter system.

2. Ensure that the backwash line is open so that water is free to come from the pool and flow out the backwash line. Set the valve in backwash position.

3. Make sure the pump pot is full with water before starting the pump.

Keep all air vents on underside of motor (or motor enclosure) free of debris to ensure proper cooling of motor.

**WARNING**

Never run the pump dry. Running pump dry may damage the seals and pump housing. This could allow water leakage and flooding.

**WARNING**

Air entering the filter and a valve clamp not closed properly can cause the valve to blow off and could cause severe bodily injury and/or property damage.

4. Check valve clamp on filter for proper assembly. (See instructions under installation section of this manual if in doubt.)

5. Open the manual air bleeder on filter. **STAND CLEAR OF THE FILTER** and start the pump allowing it time to prime.

6. Close the air bleeder on the filter when a steady stream of water emerges.

**NOTICE:** Pool Filter Sand is typically prewashed and should not require extensive backwashing. However, the shipping process may cause excessive abrasion which could require an extended backwash cycle at initial start-up; continue to backwash for 3 minutes.

**CAUTION:** To prevent equipment damage and possible injury, always turn the pump off before changing the valve position.

7. Stop the pump. Set the valve to the filter position.

8. Ensure all suction and pool return lines are open so that water is free to come from the pool and return to the pool.

9. Open the manual air bleeder on the filter. **STAND CLEAR OF THE FILTER** and start the pump.

10. Close the air bleeder on the filter when a steady stream of water emerges.

11. The filter has now started its filtering cycle. You should ensure that water is returning to the pool and take note of the operating pressure when the filter is clean.

#### D. Component Care

The pool pump and filter system is a very important part of your pool installation. Proper care and maintenance will add many years of service and enjoyment to the pool. Follow these suggestions for long trouble free operation.

1. To clean the exterior of the pump and filter system of dust and dirt, wash with a mild detergent and water and then hose off. Do not use solvents.

2. If internal filter maintenance is required, sand may be removed by removing the entire drain spigot from the bottom of the filter and flushing with a garden hose.

#### ⚠ WARNING

Always visually inspect system components during normal servicing to ensure structural safety. Replace any item which is corroded, bent or otherwise visually defective. Defective filter components can allow the filter top or attachments to blow off and could cause severe bodily injury or property damage.

3. Your filter is a pressure vessel and should never be serviced while under pressure. Always relieve tank pressure and open air bleeder on filter before attempting to service your filter.

4. When restarting your filter always open the manual air bleeder on the filter and STAND CLEAR OF FILTER.

5. The strainer basket in the pump should be inspected and cleaned twice each week. Remove the clear lid and the basket, and clean debris from basket. Inspect the lid o-ring; if damaged, replace. The pump seal requires no lubrication. The motor should only be serviced by a motor service center.

#### E. Cleaning Frequency

1. The filter on a new pool should be backwashed, and cleaned after the first 48 hours of operation to clean out construction debris.

2. There are three different ways to identify when the filter needs backwashing:

A) The most accurate indicator on pool systems with a flow meter-is to backwash when the flow decreases 30% from original (clean filter) flow. For example, if the original flow was 60 GPM, the filter should be backwashed when the flow is reduced by about 20 GPM (or 30%) to 40 GPM.

B) A more subjective and less accurate indicator is to observe the amount of water flowing from the flow

directionals located in the wall of the pool. The filter should be backwashed once it is detected that the flow has been reduced.

C) The most commonly used but least accurate indicator is to backwash when the filter gauge reading increases 10 psi over the initial (clean filter) reading.

3. It is important not to backwash the filter solely on a timed basis such as every three days. It is also important to note that backwashing too frequently actually causes poor filtration. Factors like weather conditions, heavy rains, dust or pollen, and water temperatures all affect the frequency of backwash. As you use your pool, you will become aware of these influences.

#### F. Filter Backwash Procedure

**CAUTION:** To prevent equipment damage and possible injury, always turn off pump before changing valve positions.

1. Stop pump.
2. Ensure that the suction and backwash lines are open so that water is free to come from the pool and flow out the backwash line. Set control valve to backwash position.
3. STAND CLEAR OF FILTER and start pump.
4. Backwash filter for approximately 3 minutes or until backwash water is clean.
5. Stop pump and set valve to rinse position.
6. STAND CLEAR OF FILTER and start pump.
7. Rinse filter for approximately 30 seconds.
8. Stop pump and set valve to filter position.
9. Ensure that pool return line is open so that water may flow freely from the filter back to the pool.
10. Open manual air bleeder on filter. STAND CLEAR OF FILTER and start pump.
11. Close manual air bleeder on filter when a steady stream of water emerges from the bleeder.
12. The filter has now started its filtering cycle. You should ensure that water is returning to the pool and take note of the filter pressure.
13. The filter pressure in step 12 above should not exceed the pressure originally observed on the filter when it was initially started. If after backwashing, the pressure is 4 to 6 psi above the start condition it will be necessary to chemically clean the sand bed.

#### G. Chemical Cleaning

1. It is recommended that one of the following cleaners be used:

FILTER-CLEANSE - Great Lakes Biochemical  
 FILTER-FREE - Hydrotech Chemical Corp.  
 KLEEN-IT - BioLab, Inc.

These cleaners will remove oils, scale and rust

from the sand bed in one cleaning operation.

2. Mix a solution following the manufacturer's instructions on the label.

3. Backwash the filter with the valve as outlined above.

4. If filter is below pool level, shut off pump and close appropriate valving to prevent draining the pool.

5. Shut off pump, open filter drain and allow filter to empty. Place valve in backwash position.

6. After filter has drained, close filter drain and remove the pump strainer pot lid.

7. Ensure that the backwash lines are open.

8. Turn the pump on and slowly pour the cleaning solution into the pump strainer with the pump running. If filter is below pool, open shut off valve slightly to allow pump to run.

9. Continue adding solution until the sand bed is saturated with cleaning solution.

10. Shut off the pump and leave filter in backwash position. Allow filter to stand overnight ( 12 hours).

11. Replace the pump lid and follow backwash procedure outlined above.

12. Do not allow the cleaning solution to get into the pool.

#### H. Replacement of Valve Top and Diverter Assembly

Should the filter control valve stop functioning properly, the problem can usually be corrected by replacing the top and diverter assembly as described below.

1. Shut off pump and open air bleeder to relieve all internal pressure.

2. Set valve handle to winterize position.

3. Remove 6 cover screws, washers and nuts.

4. Lift off valve top and diverter assembly.

**NOTICE:** Valve diverter assembly has the sealing gasket attached to the diverter. When handling the diverter use caution to prevent the sealing surface from being damaged during handling.

5. Clean valve body sealing surface with a soft clean lint free cloth. Inspect surface for damage such as scratches or nicks. If surface is damaged, the valve body must be replaced.

6. Carefully lubricate the new valve top replacement O-Ring with a silicone based lubricant or soapy water. Do Not use Vaseline or a petroleum based lubricant.

#### ⚠ WARNING

Improper tank valve assembly could cause the valve to blow off and cause severe injury or property damage.

7. Place the new valve top handle in the winterize position. Install new valve top and diverter assembly making sure small recess on lid and small bump on valve body are aligned. Install all 6 screws with backup washer under the screw head. Use nuts on each screw and finger tighten all 6 screws.

Screws should be tighten progressively by tightening diametrically opposite screws and following a criss cross pattern. Tighten all 6 valve top attachment screws snug. DO NOT OVER TIGHTEN.

#### I. Winterizing The Components

**NOTICE:** Allowing water to freeze in the system will damage the system and cause potential water damage/flooding and potential property damage.

1. In areas that have freezing winter temperatures, protect the pool equipment by backwashing the filter.

2. After backwashing, shut the pump off, open the manual air bleeder on the valve and move the handle to winterize position.

3. Remove the wing-type plug on the bottom of the filter. The filter will drain very slowly, and therefore, it is recommended that the drain plug be left out during the shutdown season.

**NOTE:** The Multiport Valve should be left in the winterize position during the shutdown season so the valve diverter has no pressure on the rubber seal.

4. Drain all water from the pump housing and piping when freezing temperatures are expected. Remove both drain plugs from the pump to ensure the pump will drain completely.

5. If the pump can be removed and placed in an inside dry location this should be done.

6. For an outdoor unprotected location it is best to protect the equipment in a weather proof enclosure.

7. We recommend covering the equipment with a tarpaulin or plastic sheet to inhibit deterioration from weather. DO NOT WRAP PUMP MOTOR WITH PLASTIC because condensation could form inside the motor.

8. In installations where the pump cannot be drained a 40% propylene glycol 60% water solution will protect to -50 degrees F.

**NOTICE:** Do not use anti-freeze solutions except Propylene Glycol; as other anti-freeze is highly toxic and will damage the pump.

**SWIMMING POOL PUMP AND FILTER SYSTEM**

**READ AND FOLLOW ALL SAFETY INSTRUCTIONS**