

BILTMOR DECK 5050

Contents of the Biltmor box SKU # 5050

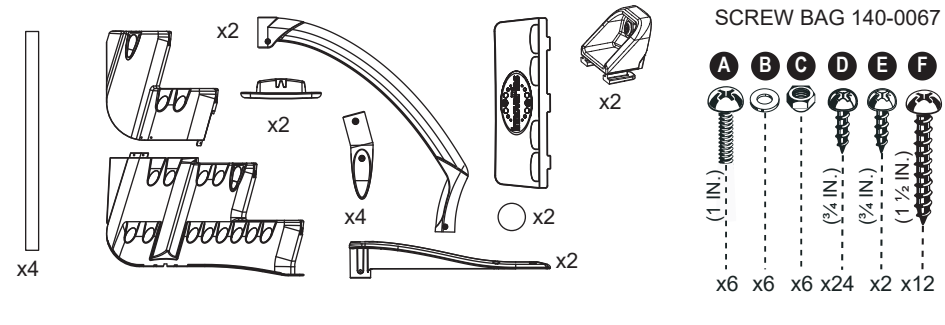

Contents Riser kit

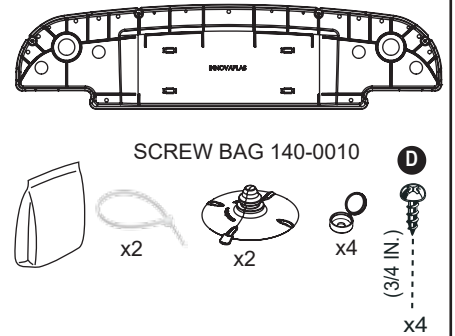

⚠ WARNING

- ▶ Install the step on a flat surface.
- ▶ Do not jump or dive from the step.
- ▶ Remove the step from water when temperatures drop below freezing.
- ▶ In winter, the step should be stored in an area protected from snow.
- ▶ Never lift the step by its handrails.
- ▶ Use BATTERY operated tools to avoid electric shock near water.
- ▶ Ensure no corrosive materials are added to the step or hardware kit.
- ▶ The step must be installed per manufacturer's instructions.
- ▶ File off all stripped or sharp edges before assembly to avoid injuries and liner damage.
- ▶ The manufacturer is not responsible for damages or injuries caused by improper installation or use of product.
- ▶ To ease the installation of handrails and bolts, use a screwdriver to line up the holes.

Required tools (not included)

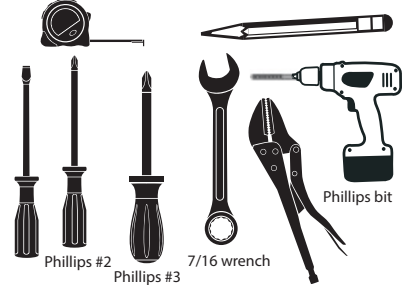

Sand

(not included)

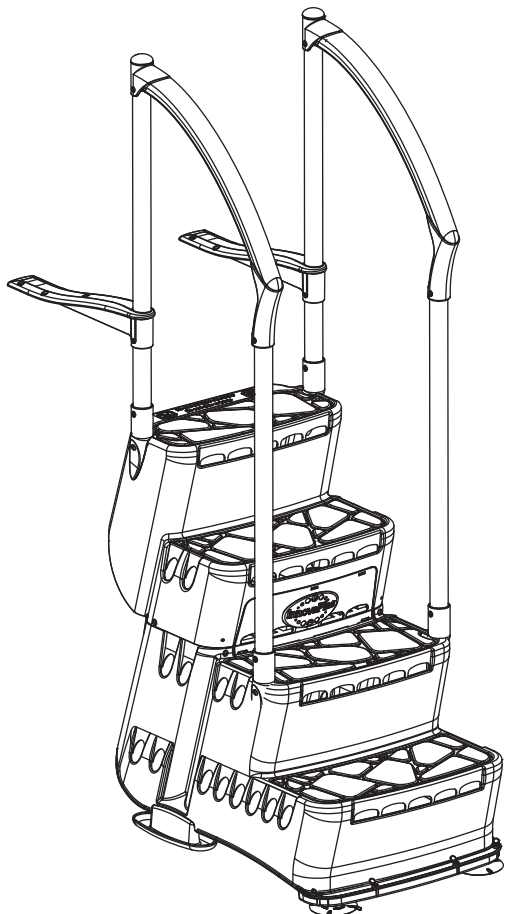

A

- 1) Insert the two gussets in the slots and slide them toward the corners.
- 2) Assemble the two main modules with the six screws, nuts and washers provided.
- 3) Snap the door between the top and bottom module within the slots provided.

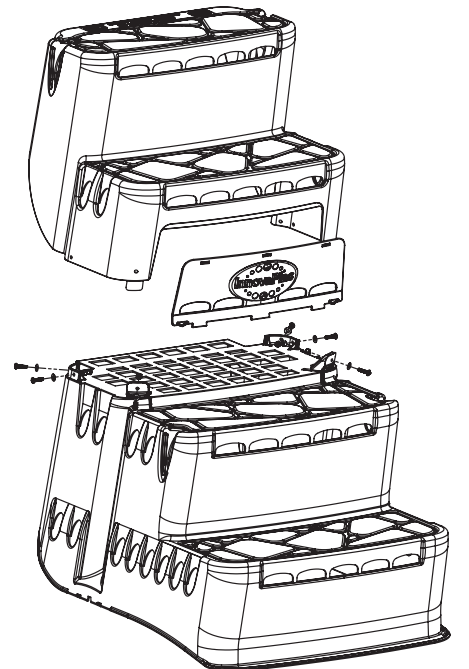
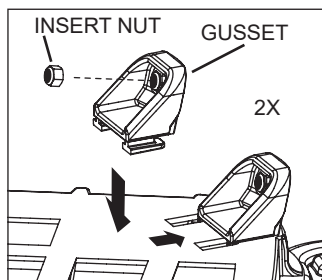
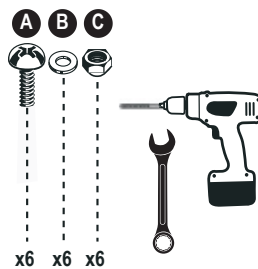

MANUFACTURER WARRANTY

**1 year on pool step.
1 year on hardware.**



2257 route 139
Drummondville, Québec
J2A 2G2

WWW.INNOVAPLAS.COM

REV. 02/26/2020

PN:

PG:1

BILTMOR DECK 5050

B

1) Snap the four post ends into the step, making sure that the cylindrical part is vertical and that the ends are snapped properly in their respective housings.

2) Snap the two feet to the bottom of the step.

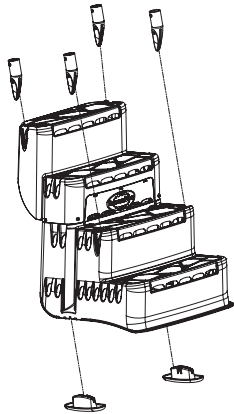

C

1) Fill the bag provided with sand. The approximate weight should be 5 lbs.

*Sand not included

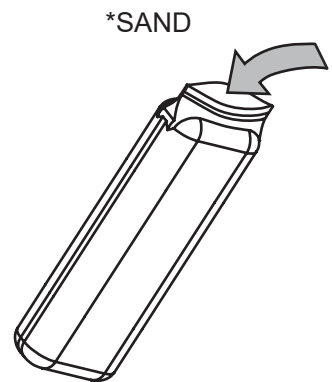

D

1) Slide the two tie wraps in place and place the sand bag into the riser. Fasten the tie wraps. Do not over tighten.

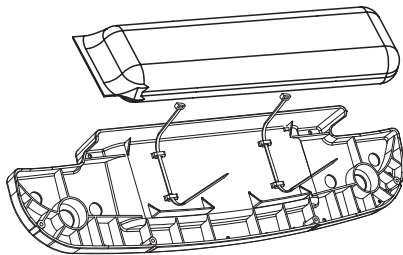

E

- 1) Insert the two step cups in the riser.*
- 2) Place the riser on the ground, install the step on top of the riser and fasten with the four screws and plastic screw caps provided.
- 3) Snap the screw caps covers in place.



* View step cups installation tips on YouTube:
<https://www.youtube.com/watch?v=W5RH1VNxpu0>

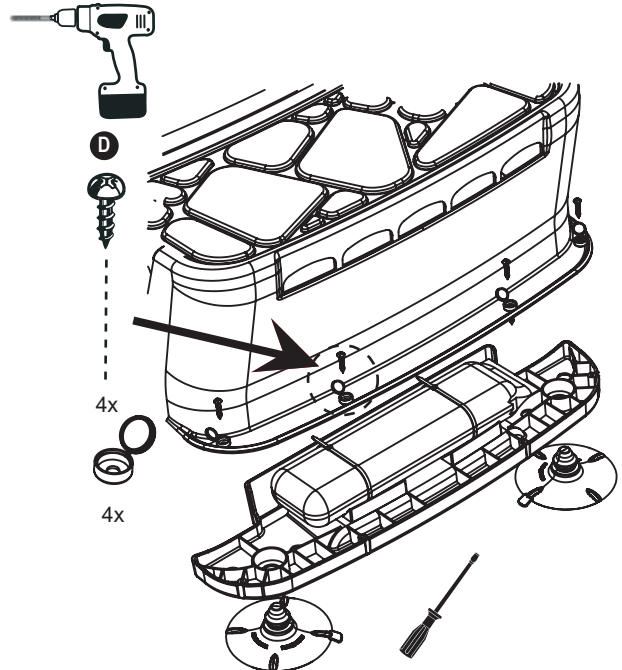

F

- 1) Insert the four posts into the post ends and secure them in place with the screws provided (see medallion).
- 2) Insert the two deck supports over the rear posts.
- 3) Insert the handrails on the two posts and secure in place.
- 4) Fasten the access panel with the screws provided.

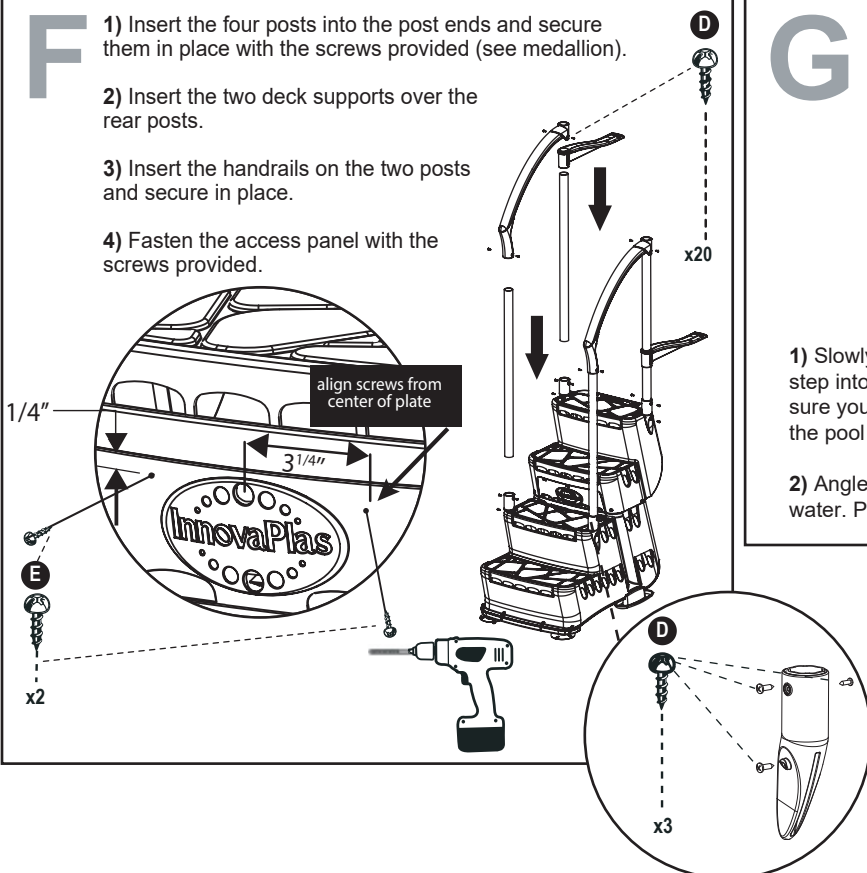

G

1) Slowly submerge the step into the pool. Make sure you do not damage the pool liner in the process.

2) Angle the whole step so that it is entirely under water. Purge all the air from under the step.

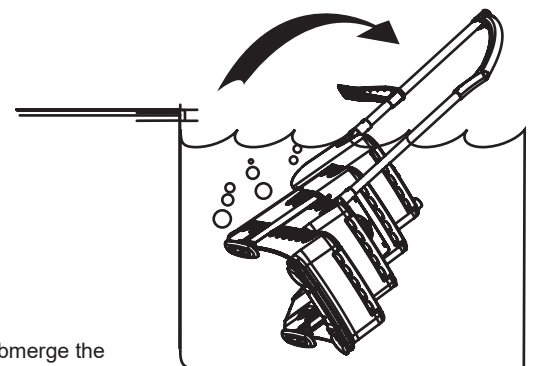

MANUFACTURER WARRANTY

**1 year on pool step.
1 year on hardware.**

BILTMOR DECK 5050

H

1) Affix the deck supports to the deck with the screws supplied.

2) Install the two post covers.

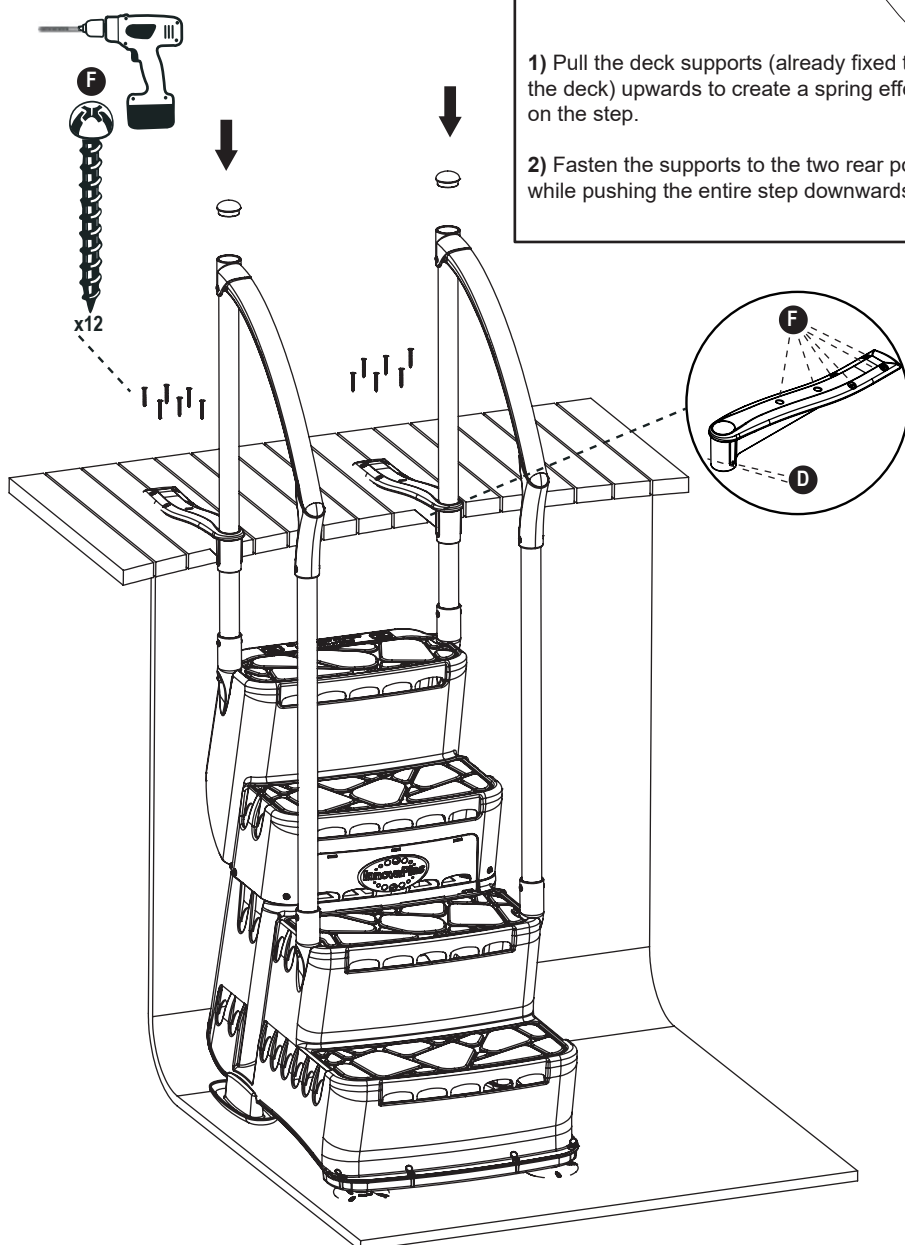

I

-
- Diagram I illustrates the adjustment of deck supports. It shows a power drill and a screw labeled 'D'. A circular inset shows the support being pulled up and then pushed down into a post. A quantity of 'x4' is indicated for the screws.
- 1) Pull the deck supports (already fixed to the deck) upwards to create a spring effect on the step.
 - 2) Fasten the supports to the two rear posts while pushing the entire step downwards.

MANUFACTURER WARRANTY

**1 year on pool step.
1 year on hardware.**