



PowerLine *XP III*

Swimming Pool Pump (Black color model)

UL Models w/GFCI

0-3496-200 (1 HP), 0-3497-200 (1-1/2 HP)

NEC Models

0-3496-206 (1 HP), 0-3497-206 (1-1/2 HP)

Owner's Guide



PREPARATION

IMPORTANT SAFETY INSTRUCTIONS

FOR ALL MODELS:

When installing and using this electrical equipment, basic safety precautions should always be followed, including the following:

1. **READ AND FOLLOW ALL INSTRUCTIONS.**
2. **WARNING:** To reduce the risk of injury, do not permit children to use this product unless they are closely supervised at all times.
3. **WARNING:** Risk of electric shock. Connect only to a grounding type receptacle protected by a Ground Fault Interrupter (GFCI).
(For storable pool pumps) This product is provided with a ground-fault circuit-interrupter. If replacement of the plug or cord is needed, use only identical replacement parts.
(For all permanently installed units) Connect only to a branch circuit protected by a ground-fault circuit-interrupter (GFCI).
Contact a qualified electrician if you cannot verify that the receptacle is protected by a GFCI.
4. Do not bury cord. Locate cord to minimize abuse from lawn mowers, hedge trimmers, and other equipment.
5. **WARNING:** To reduce the risk of electric shock, replace damaged cord immediately.
6. **WARNING:** To reduce the risk of electric shock, do not use an extension cord to connect unit to the electrical supply; provide a properly located outlet.

FOR UL MODELS: (25 Ft. cord)

7. **CAUTION:** This pump is for use with storable pools only. Do not use with permanently installed pools. A storable pool is constructed so it may be readily disassembled for storage and reassembled to its original integrity. A permanently installed pool is constructed in or on the ground or in a building such that it cannot be readily disassembled for storage.
(For storable pools) The unit is provided with a ground-fault circuit-interrupter (GFCI). To test the GFCI, push the test button. The GFCI should interrupt power. Push the reset button. Power should be restored. If the GFCI fails to operate in this manner, the GFCI is defective. If the GFCI interrupts power to the pump without the test button being pushed, a ground current is flowing, indicating the possibility of an electric shock. Do not use the pump. Disconnect the pump and have the problem corrected by a qualified service representative before using.

FOR NEC/UL MODELS ONLY: (3 Ft. cord)

8. **CAUTION:** This pump is for use with permanently installed pools and may also be used with hot tubs and spas if so marked. Do not use with storable pools. A permanently installed pool is constructed in or on the ground or in a building such that it cannot be readily disassembled for storage. A storable pool is constructed so that it may be readily disassembled for storage and reassembled to its original integrity.

FOR ALL MODELS:

9. SAVE THESE INSTRUCTIONS.

ELECTRICAL SOURCE

FOR UL MODELS: (25 Ft. cord)

Your pump is supplied with a 25 foot, 3-wire electrical cord and a 3-pronged plug. The pump is double insulated and grounded. The pump electrical cord must be connected to a grounded, 3-wire, 115 VAC electrical receptacle.

The pump should be connected to a receptacle on a dedicated circuit protected by a 20 AMP circuit breaker. **DO NOT** use a grounding adaptor.

The receptacle must be protected by a Ground Fault Circuit Interrupter (GFCI) in accordance with Article 680-31 of the National Electrical Code (NEC), (Section 68-204 of the Canadian Electrical Code (CSA) and local codes or ordinances. For runs greater than 25 feet, consult your local licensed electrical contractor.

FOR NEC/UL MODELS ONLY: (25 Ft. cord)

Your pump is supplied with a 3-foot, 3-wire electrical cord and a 3-prong flanged, twist-lock plug. The pump electrical cord must be connected to a single twist lock, grounding type receptacle that is located a minimum of 6 feet from the inside pool wall.

A qualified electrical contractor must install this receptacle in accordance with Article 680-6 of the National Electrical Code (NEC). A Ground Fault Interrupter (GFCI) must be used. An ON/OFF Switch must be installed at the receptacle.

Use a Hubbell No. 2310 Receptacle, 20 AMP 125 Volt A.C. or an equivalent receptacle that meets NEMA Configuration L5-20R.

This pump is double insulated and grounded. Dead metal parts are not in contact with pool water.

CAUTION

1. **DO NOT** install the pump on a deck, it could fall into the water, causing severe electrical shock. Do not install on any surface at, above, or slightly below the top rail of the pool.
2. **DO NOT** allow children or adults to climb, sit, or stand on the pump unit. They could easily fall. Position the filter and pump approximately 6 feet from the pool wall so they may not be used as steps by children.
3. Always keep the water level in your pool between the water level markers on the skimmer face plate. If the pump is run with water level too low, the pump seal may overheat and cause permanent damage to the pump.
4. Your Powerline pump must sit in its pump base, on a patio block, or on any firm surface that slightly elevates the pump off the ground. This keeps water away from the motor and prevents the vents of the Power Pak from becoming blocked, which could cause the motor to overheat.

SUCTION AND DISCHARGE CONNECTIONS

Your Powerline pump is provided with two union socket connections for hard plumbing to 1-1/2" PVC pipe or flex pipe and two union hose adaptors for connecting to 1-1/2" inside diameter hose. Install o-ring into groove on end of the body outlets, then position either the union socket or hose adaptor and secure in place with the union nut.

NOTE: Use ABS to PVC solvent cement when using the union socket connections for hard plumbing installations. Refer to the solvent manufacturer's instructions for preparations of socket and pipe end and solvent welding of the joints.

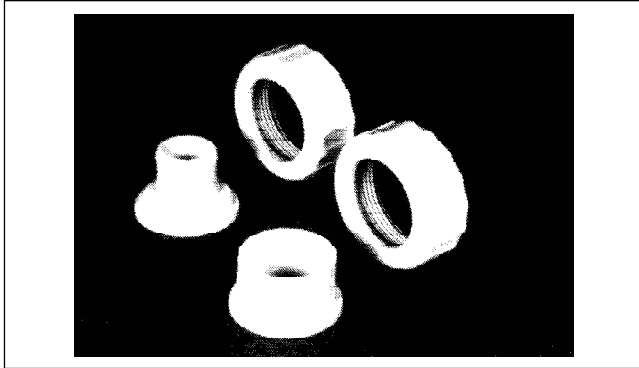

SHUT-OFF VALVE

Your Powerline pump features a shut-off valve in the pump suction inlet. This feature allows you to shut off the flow from the skimmer when removing strainer basket for cleaning or servicing the pump.

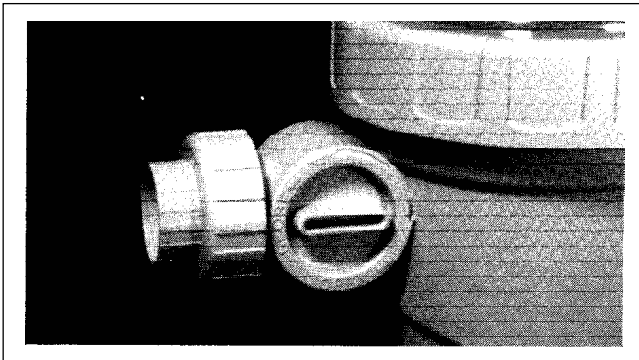

Rotate valve knob counter-clockwise until it stops (open position) for normal pumping operation.

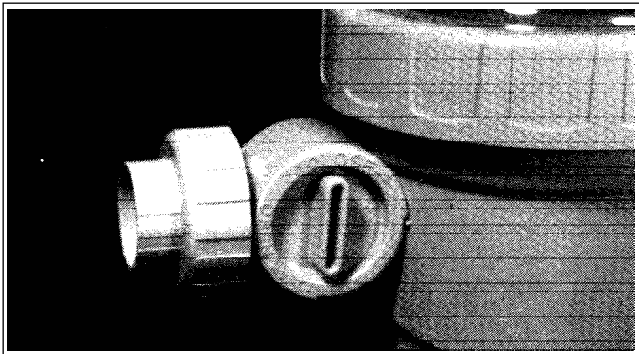

Rotate valve knob clockwise until it stops (closed position) when cleaning out the strainer basket or servicing the pump.

MAINTENANCE

Make sure the pump is disconnected from the electrical source before attempting any maintenance work.

LUBRICATION

Periodically lubricate the O-Ring under the strainer cover with a NON-PETROLEUM lubricant recommended for A.B.S. and Lexan plastics. Consult your pool dealer for lubricant selections.

If you have any questions or require assistance, contact your Doughboy pool dealer.

CAUTION

Fingers can become wedged where Strainer Lid and Union Fitting intersect. Please use caution when removing the Strainer Lid.

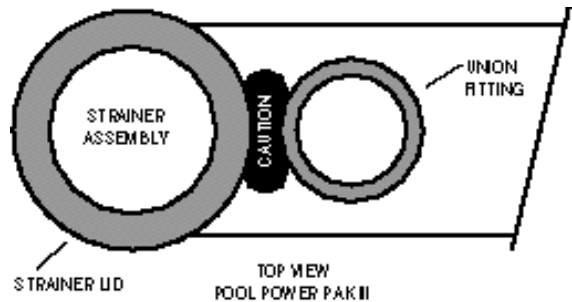

SERVICING SAFETY TIPS

- A. **ALWAYS TURN "OFF"** the main power switch and the Ground Fault Circuit Interrupter (GFCI) breaker switch so power is completely off before servicing your unit.
- B. **ALWAYS BE SURE THE GROUND UNDER YOUR FEET AND YOUR BODY IS DRY** before you touch electrical equipment. Failure to heed this warning may cause personal injury due to severe electrical shock.
- C. **ALWAYS** have a qualified electrician service your system if electrical problems occur. This system is UL listed and must be serviced by a qualified electrician to insure that the electrical integrity is maintained. Failure to do so may cause personal injury due to severe electrical shock and may void the listing and warranty.
- D. **ALWAYS** have a qualified electrician install a Ground Fault Circuit Interrupter (GFCI) breaker at the electrical service or supply panel. Follow GFCI manufacturer's operating instructions for testing. Failure to do so may cause personal injury due to severe electrical shock.

CAUTION: To reduce the risk of electrical shock, connect only to grounding type receptacles. A Ground Fault Circuit Interrupter (GFCI) must be provided in accordance with local codes or ordinances.

CAUTION: To reduce the risk of electrical shock, use only Original Equipment Manufactured (OEM) replacement parts when servicing.

EXPLODED VIEW

UL Models: 0-3496-200 (1 HP), 0-3497-200 (1-1/2 HP) w/GFCI

NEC Models: 0-3496-206 (1 HP), 0-3497-206 (1-1/2 HP)

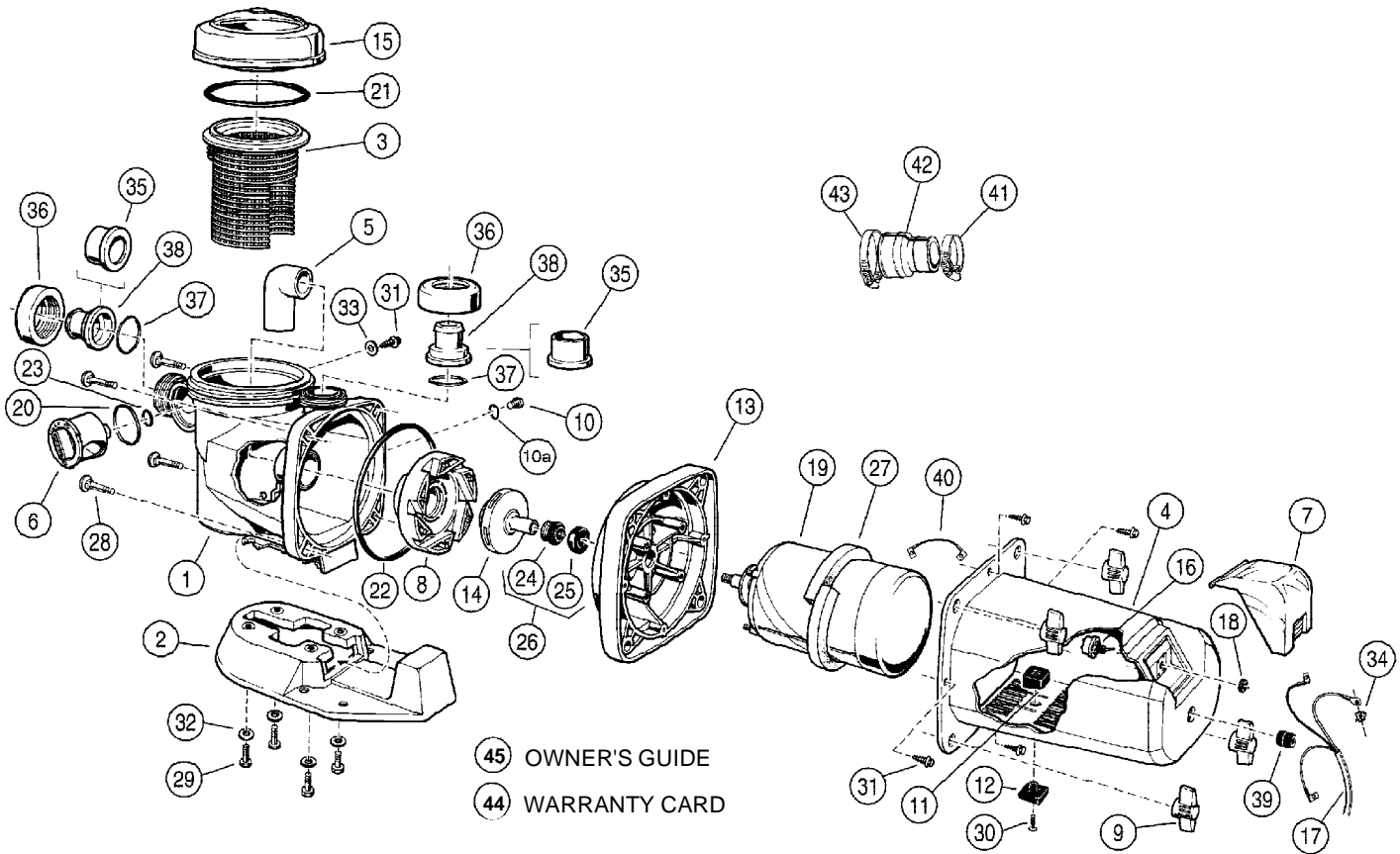

ITEM	P/N	QTY	DESCRIPTION	ITEM	P/N	QTY	DESCRIPTION
1	1121-2038	1	Strainer Housing w/Suction Tube	20	308-1227	1	O-Ring - 2.609 I.D.
2	1121-1980	1	Pump Base	21	308-1228	1	O-Ring - 6.975 I.D.
3	340-1988	1	Strainer Basket	22	308-1229	1	O-Ring - 8.475 I.D.
4	340-2590	1	Motor Housing	23	308-1009	1	O-Ring - .487 I.D.
5	—	1	Elbow Suction Tube (Part of 1121-2038)	24	308-1202	1	3/4" Shaft Seal
6	340-2591	1	Valve Shut-off Knob	25	308-1231	1	3/4" Pump Seal Seat
7	340-2004	1	Timer Cover	26	1121-1495	1	3/4" Pump Seal Set
8	340-1991	1	Diffuser	27	310-1054	1	Foam Baffle
9	340-2585	4	Strainer Knob	28	330-1239	4	3/8-16 x 2-1/2" Carriage Bolt
10	1121-2008	1	1/4" Pipe Plug w/o-ring	29	330-1219	4	5/16-18 x 1" Bolt
10a	308-1011	1	Pipe plug O-ring	30	330-1240	1	#10-24 x 1" Screw
11	1121-1497	1	Motor Housing Bumper - Top	31	330-1241	5	#10 x 5/8" Screw
12	340-2054	1	Motor Housing Bumper - Bottom	32	327-1020	4	5/16" Flat Washer
13	1107-2482	1	Backplate	33	327-1063	1	#10 Flat Washer
14	1107-1513	1	Impeller Assembly - 1 H.P.	34	327-1036	1	#8 Ext. Tooth Lockwasher
	1107-1514	1	Impeller Assembly - 1-1/2 H.P.	35	340-2485	2	Union Socket
15	1107-2483	1	Strainer Lid Assembly	36	340-2484	2	Union Nut
16	303-1109	1	Switch (UL/CSA)	37	308-1241	2	O-Ring - 1.984 I.D.
17	1100-1696	1	Power Cord - 25' GFCI	38	340-2502	2	Union Hose Adaptor
	1100-1115	1	Power Cord - UL/NEC	39	303-1715	1	Strain Relief Bushing
•	340-2607	1	Strainer cover wrench (not shown)	40	1100-1400	1	Jumper Wire (UL/CSA)
18	303-1110	1	Knurled Ring Nut (UL/CSA)	41	387-1023	1	#28 Band Clamp
19	300-1091	1	Motor - 1 H.P.	42	348-1036	1	Hard Plumb Adaptor
	300-1092	1	Motor - 1-1/2 H.P.	43	387-1024	1	#36 Band Clamp
				44	—	1	Warranty Card
				45	365-2074	1	Owner's Guide

Note: Items 41, 42 & 43 are for hard plumbing 1-1/2" PVC pipe or flex pipe to the skimmer bottom.



Change of Design: Doughboy Recreational expressly reserves the right to change or modify the design and construction of any product in due course of our manufacturing procedures, without incurring any obligation or liability to furnish or install such changes or modifications on products previously or subsequently sold.

"the original portable pool"
doughboy®

DOUGHBOY RECREATIONAL • 315 North Sebastian St. • West Helena, AR 72390
Visit our website at: www.doughboy-pools.com